

Revision History

Rev.	Description of change	Date
A	As Issue	6 September 2011

Table of content

Cover Disassembly Procedure	3
LCD Disassembly Procedure	8
Removable Hard Disk Disassembly Procedure	17
Standard Hard Disk Disassembly Procedure	21
A50 CPU module Disassembly Procedure	27
Oven (Option 1E5) Disassembly Procedure	31
A61 DSP board Disassembly Procedure	34
A80 Analog Base Module Disassembly Procedure	40
A82 Level Vernier Module Disassembly Procedure	45
A91 Synthesizer Module Disassembly Procedure	45
A2 Receiver Module Disassembly Procedure	45
A84 Local Distributor Disassembly Procedure	45
A50 Analog Motherboard Disassembly Procedure	52
A92 RF Frontend Module Disassembly Procedure	61

Cover

Dis-Assembly Procedure

Note:

1. Torque value shown in this document is only for reference and only used during assembly.

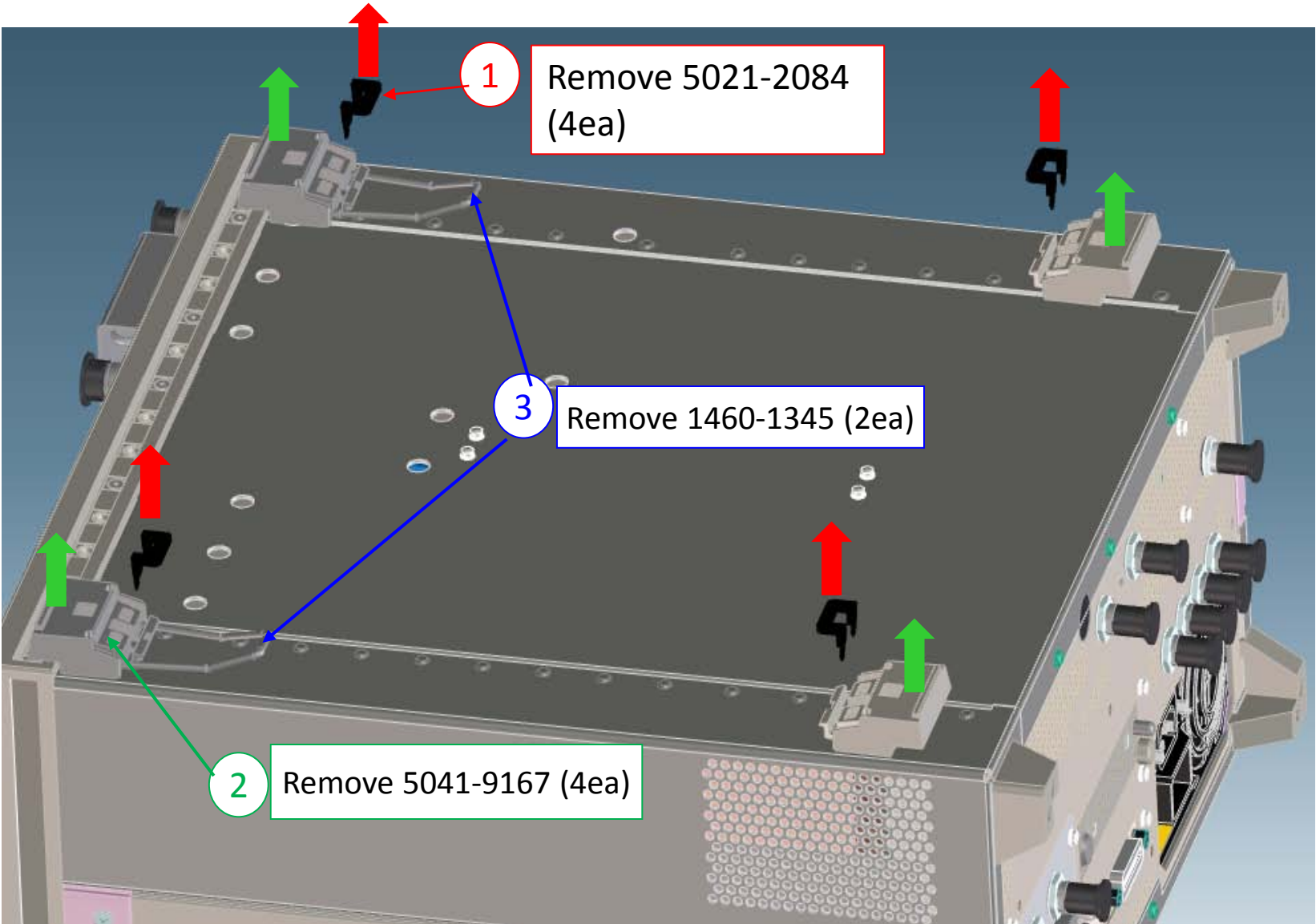

1 Remove 5021-2084 (4ea)

3 Remove 1460-1345 (2ea)

2 Remove 5041-9167 (4ea)

- 1
- 2
- 3

T20 : 14 in-lbs

Remove 0515-2049 (2ea)
5041-9187 (2ea)

Remove 08720-00081 (2ea)

Remove 0515-2049 (2ea)
5041-9186 (2ea)

T20 : 14 in-lbs

① ②

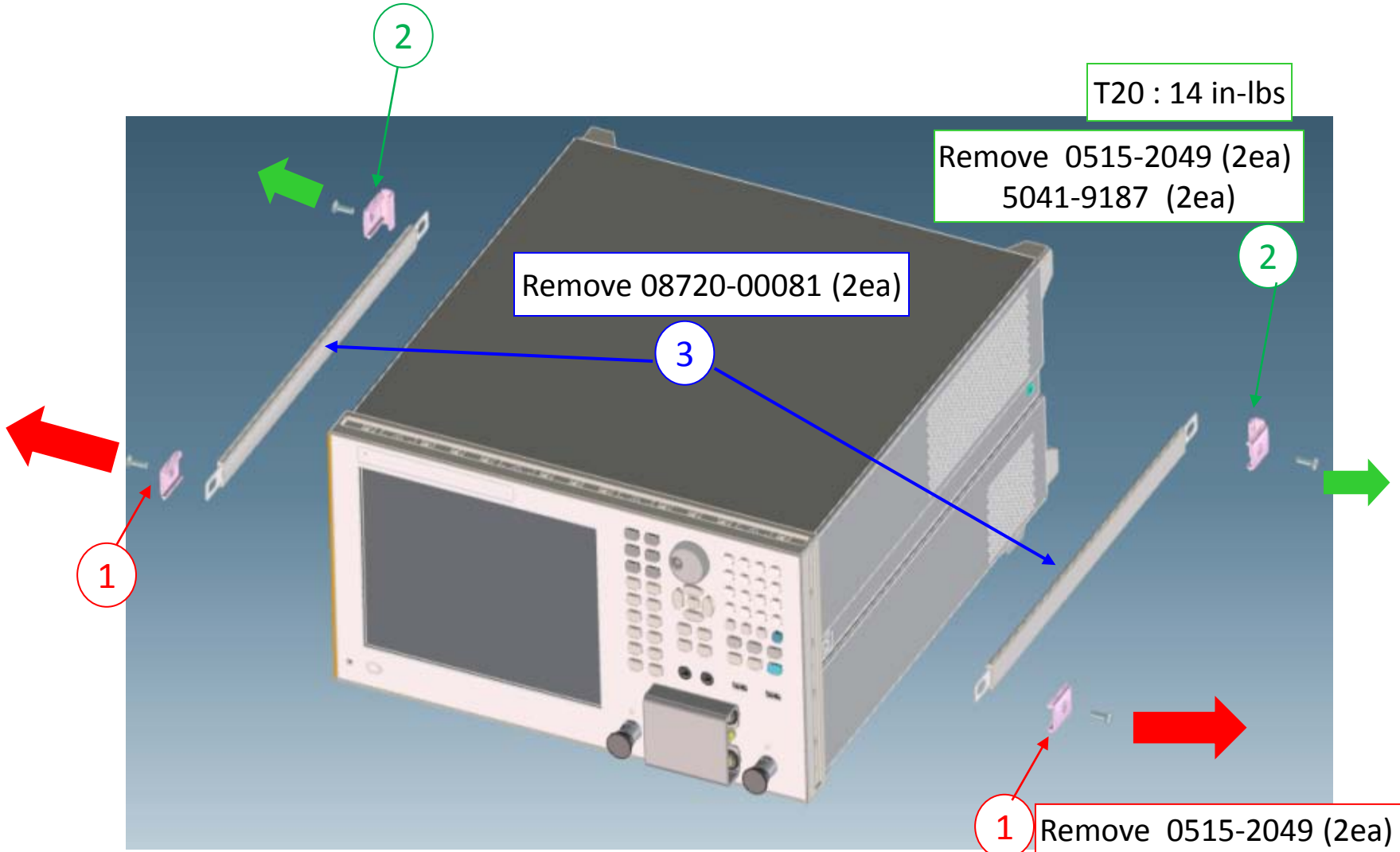

T15 : 14 in-lbs

1

Remove 0515-1402 (4ea) &
E5100-40002 (4ea)

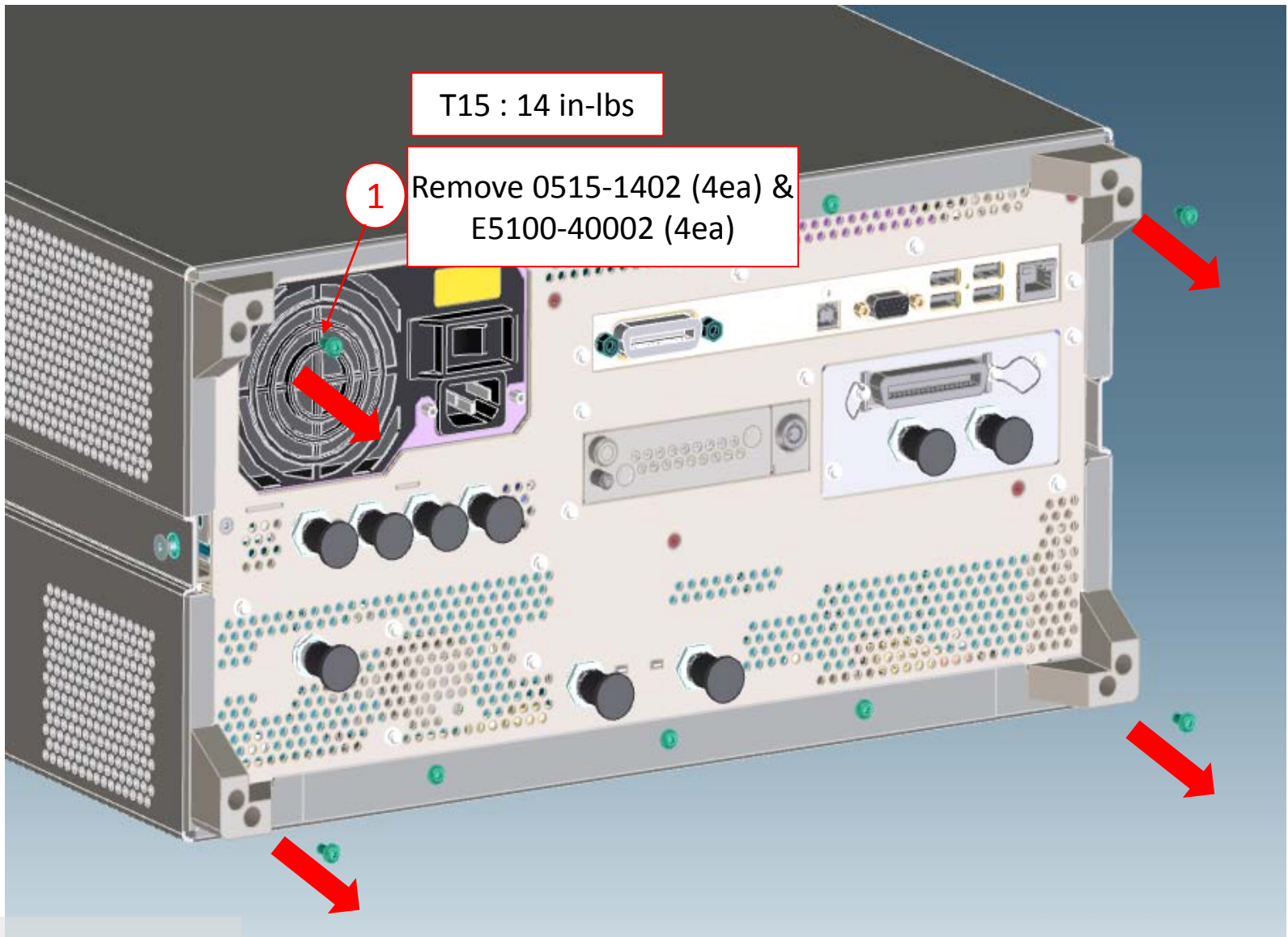

1 2

T15 : 14 in-lbs

Remove 0515-1402 (5ea)

1

T10 : 9 in-lbs

Remove 0515-0430 (2ea)

2

Remove Cover

3

1 2 3

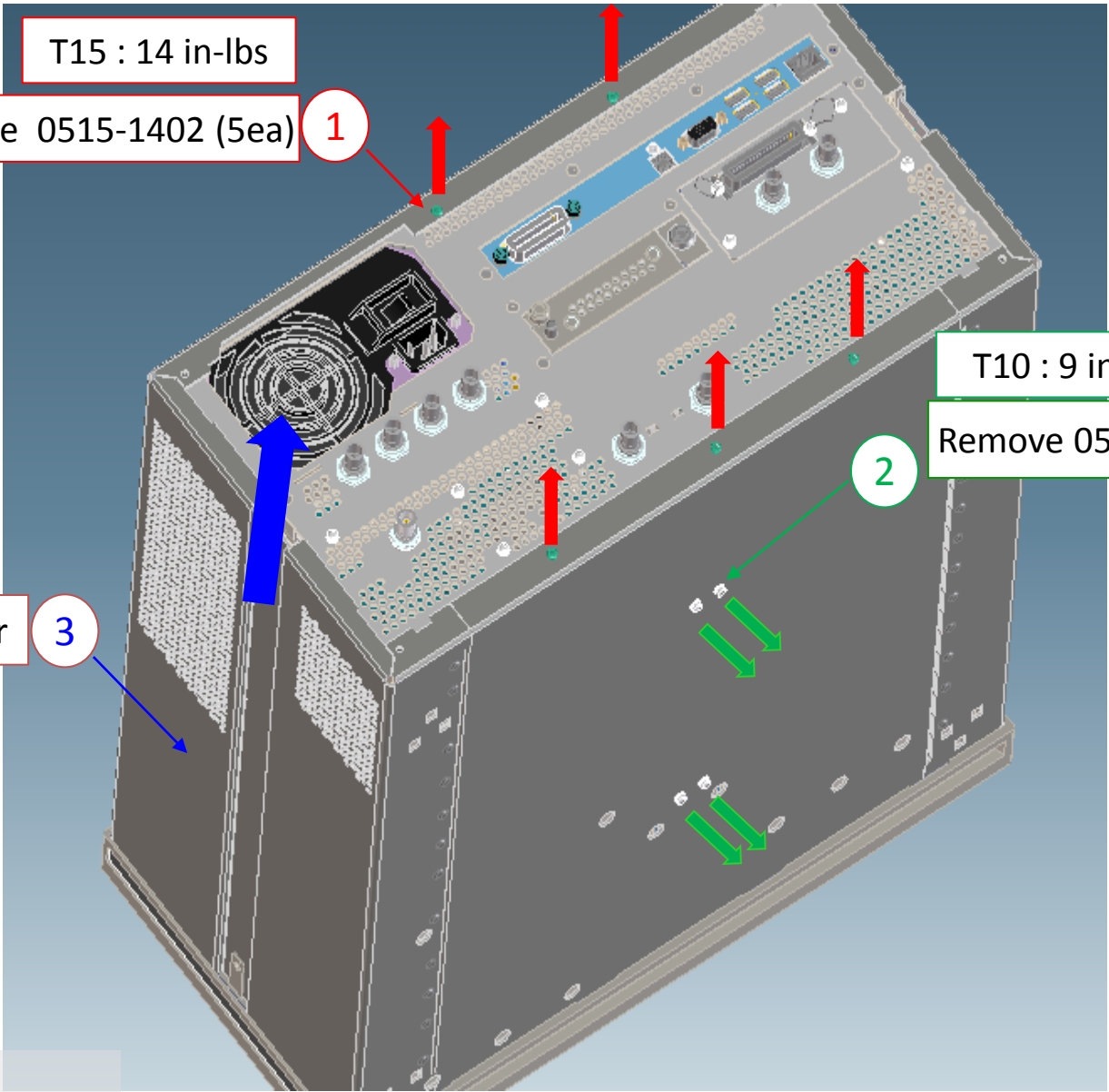

LCD (2090-0883)

Dis-Assembly Procedure

Note:

1. Torque value shown in this document is only for reference and only used during assembly.

1 Remove 5041-9176

8mm Open End :
9.5 in-lbs

Remove E8356-20072 (6 ea) 3

Remove N5242-00030 2

Hubic Cart
used in F03
production

1 2 3

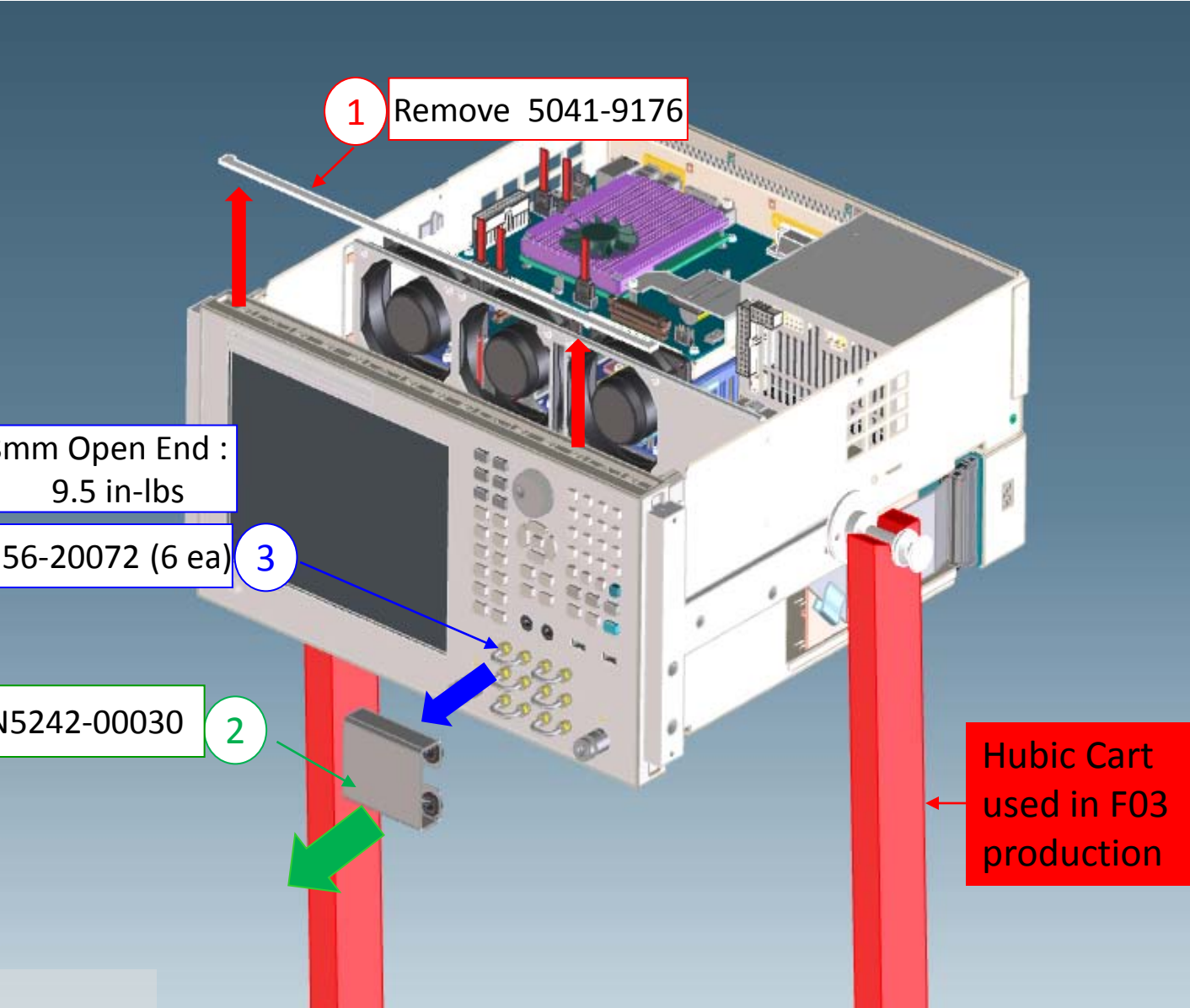

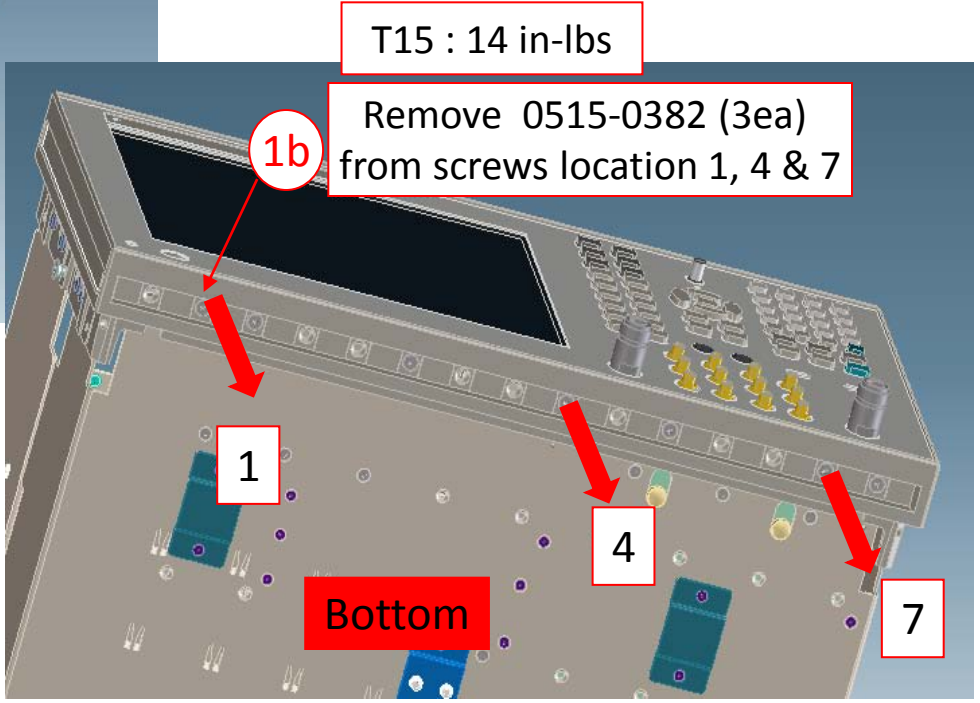
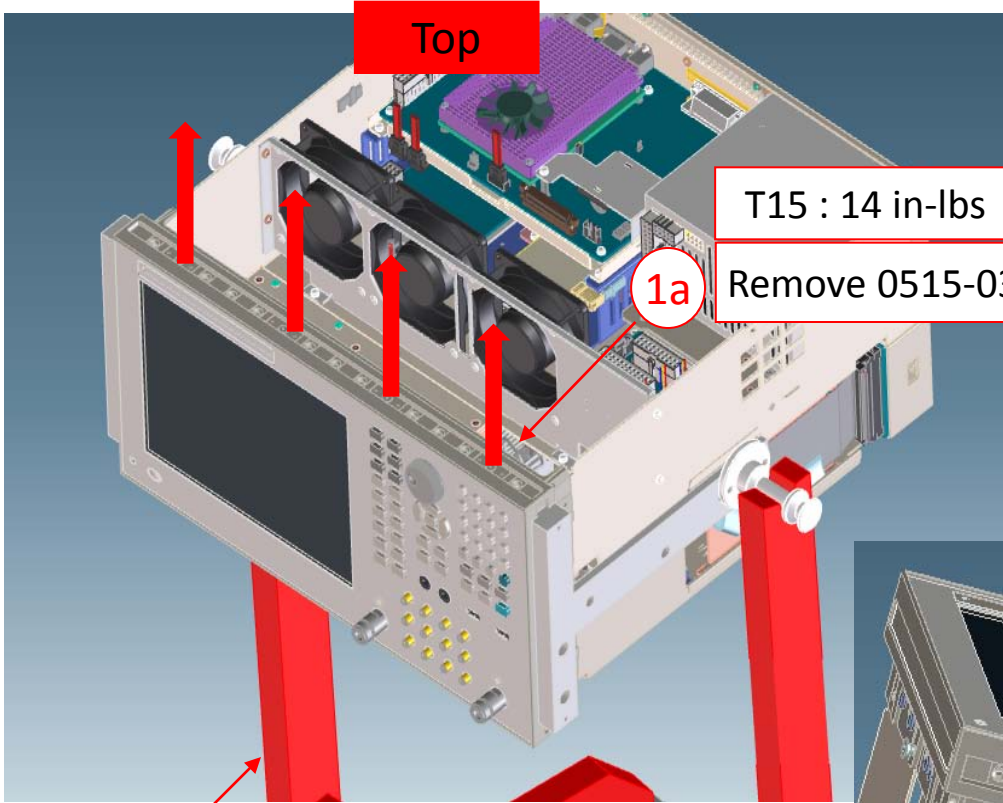

Hubic Cart
used in F03
production

1

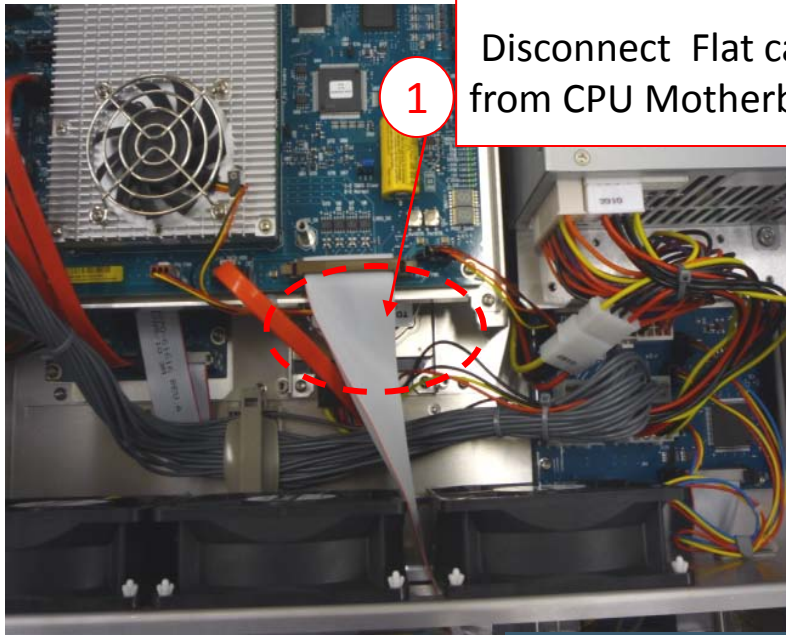

1 Disconnect Flat cable from CPU Motherboard

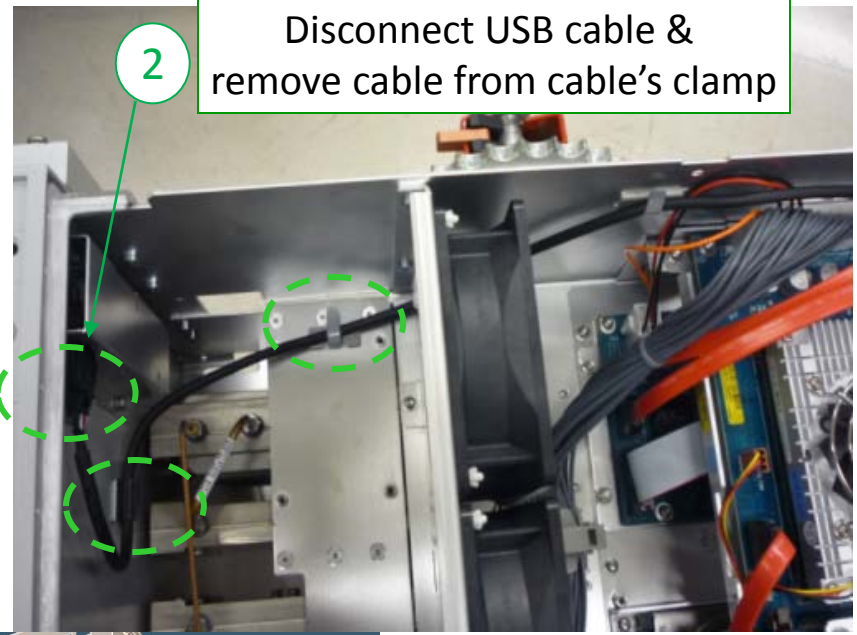

2 Disconnect USB cable & remove cable from cable's clamp

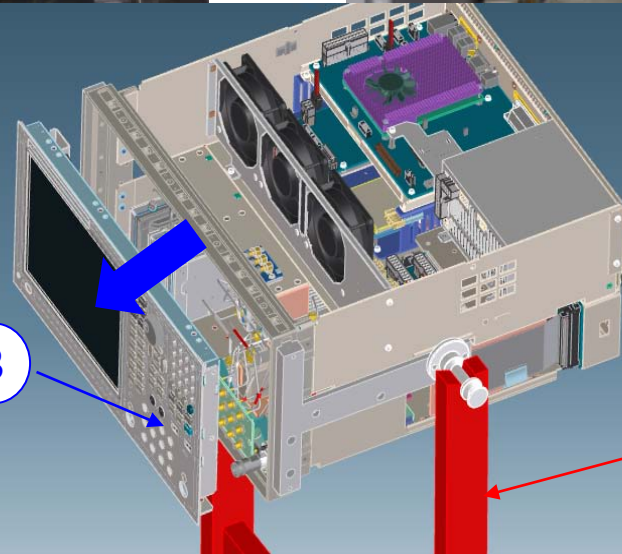

3 Slowly pull/remove Front frame Sub-assembly from Chassis

Hubic Cart used in F03 production

Open Clamp and remove Flat cable E5072-61624

1

T10 : 9 in-lbs

2

Remove 0515-0430 (1ea)

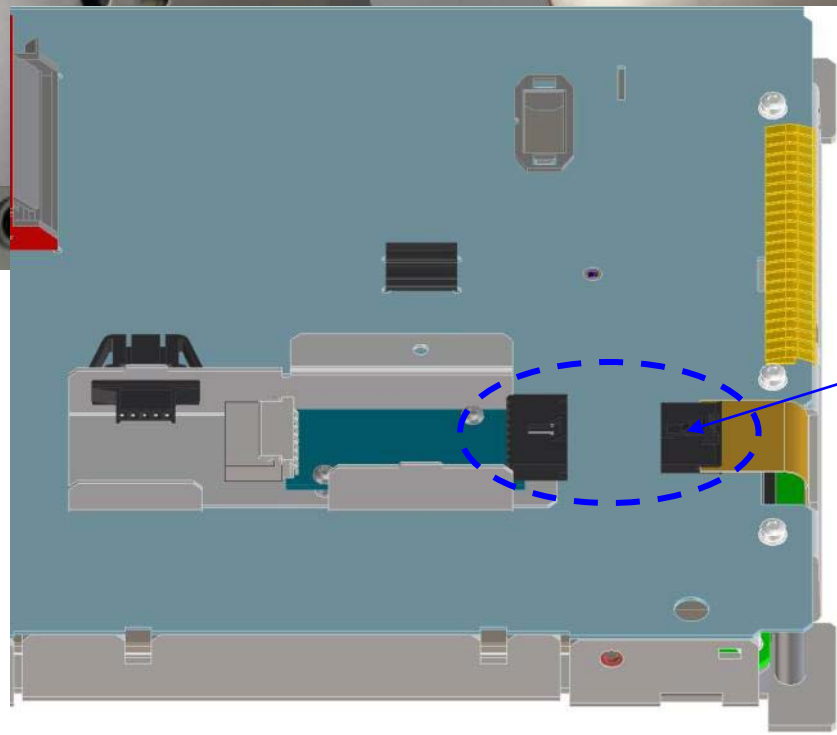
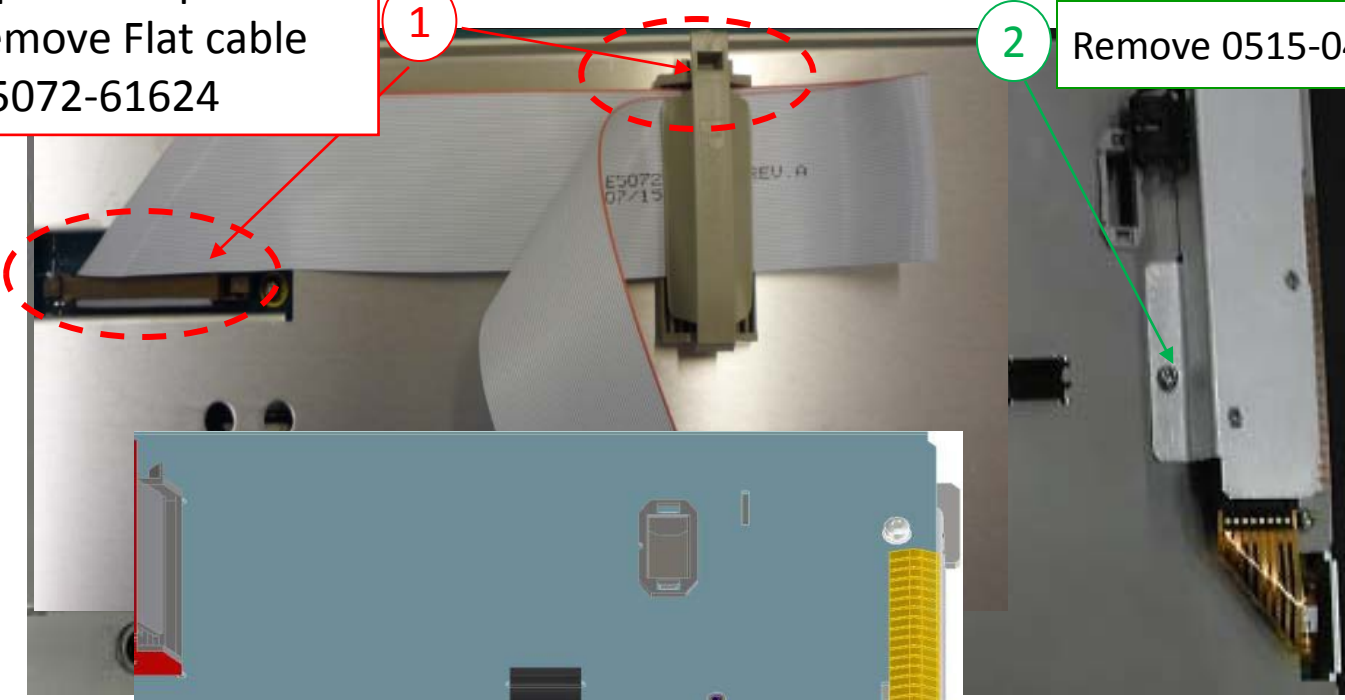

3 Disconnect flat cable from Touch Screen Controller Board

1 2 3

T10 : 9 in-lbs

1 Remove 0515-0430
(6ea)

2 Remove E5072-0060

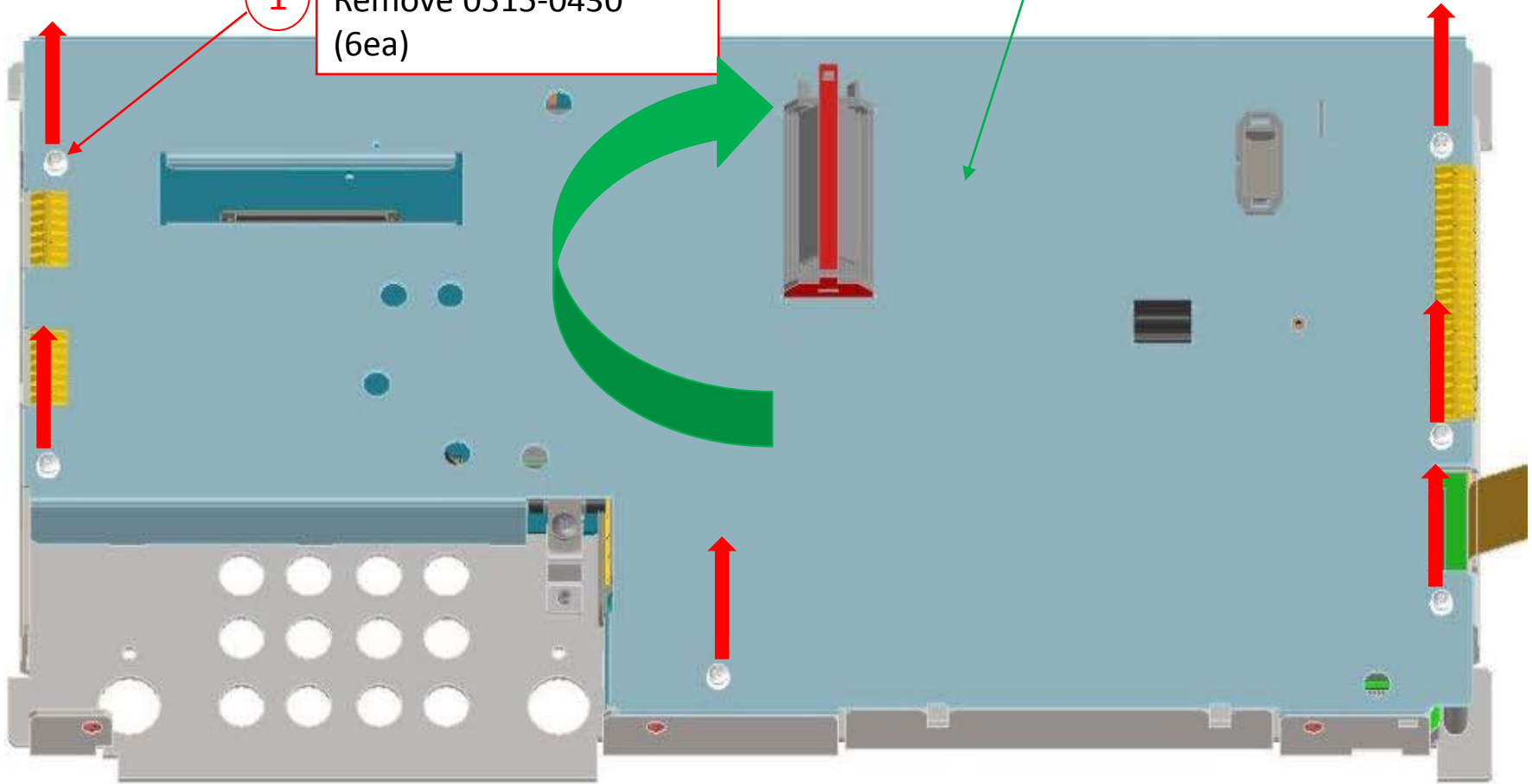

1 2

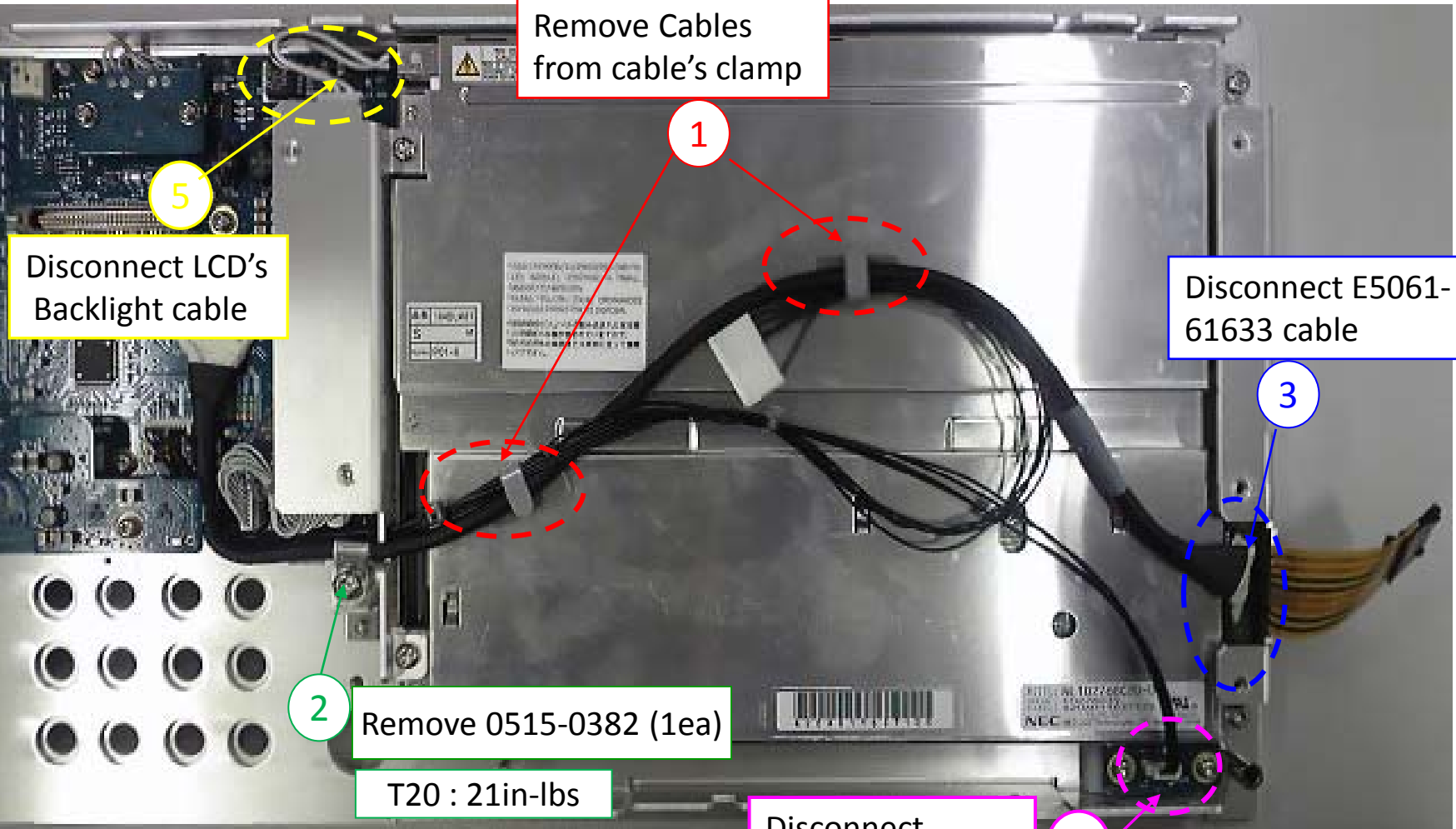

Remove Cables from cable's clamp

1

Disconnect LCD's Backlight cable

5

Remove 0515-0382 (1ea)

2

Disconnect E5061-61633 cable

3

Disconnect E5072-61625 cable

4

T20 : 21in-lbs

1 2 3 4 5

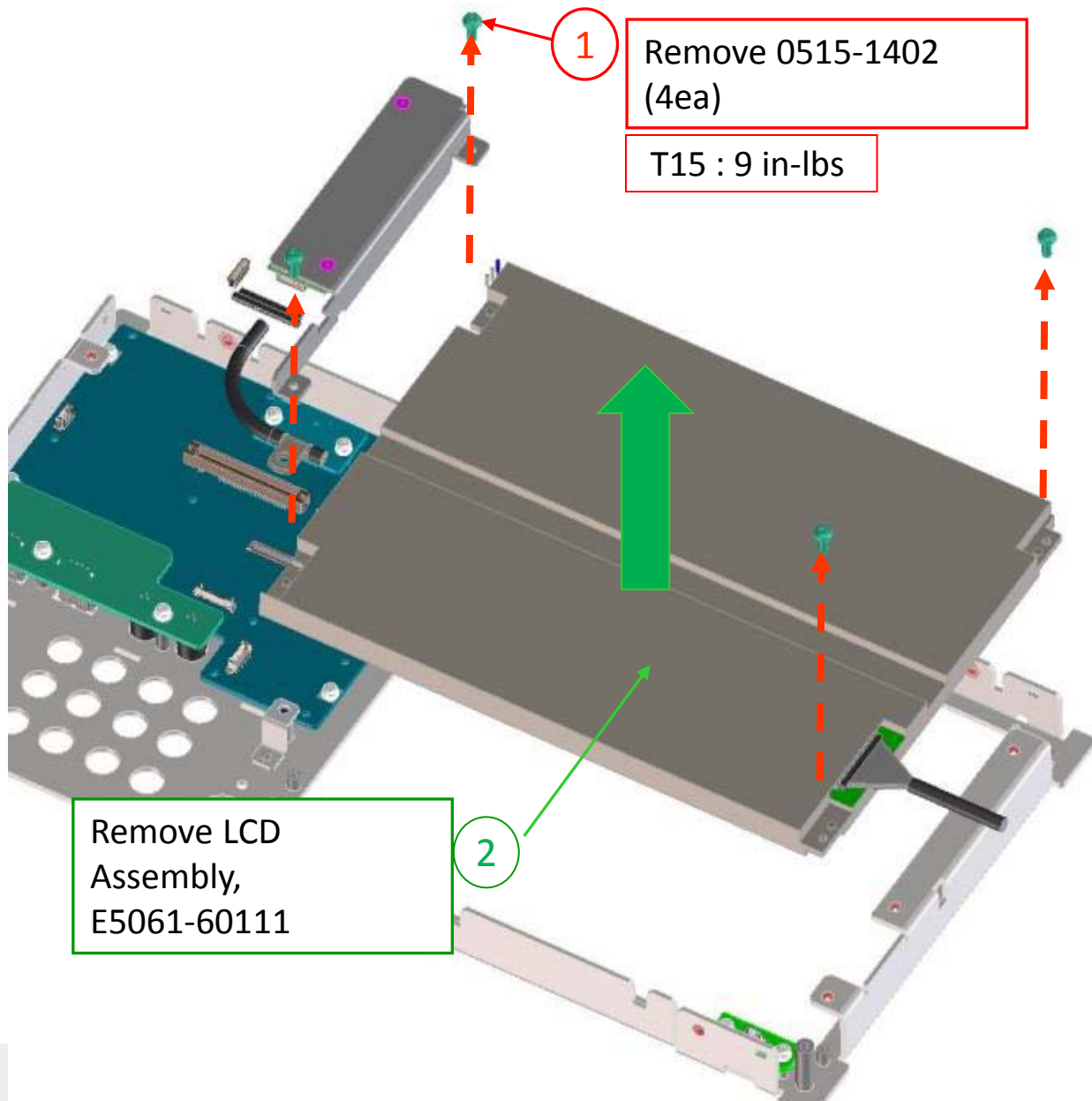

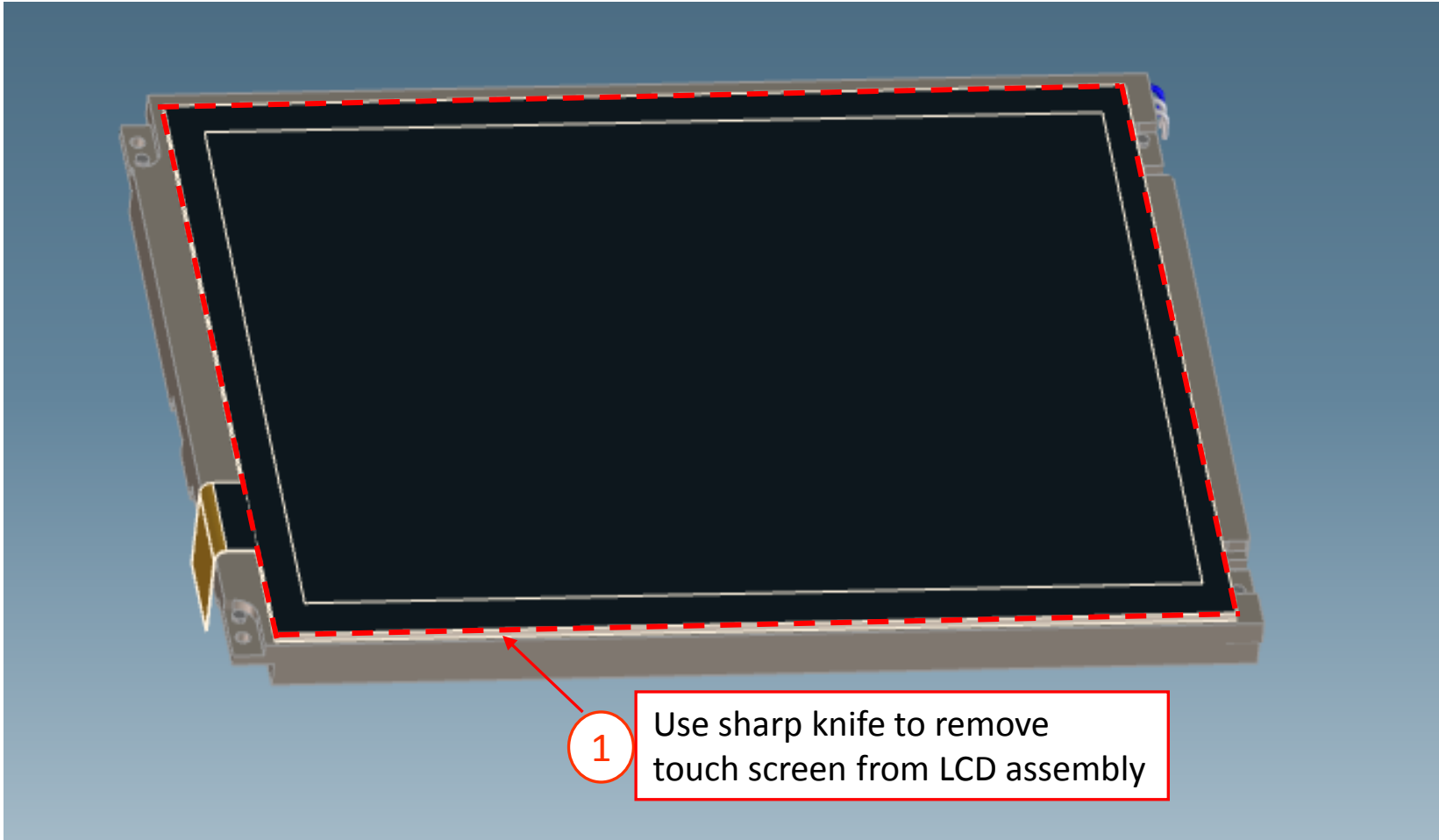

1

Use sharp knife to remove touch screen from LCD assembly

1 2

Removable Hard Disk Dis-Assembly Procedure (For Option 017 only)

Note:

1. Torque value shown in this document is only for reference and only used during assembly.

Turn Anti-Clock Wise to Loosen

2

Push Button to push out R-HDD from HDD's Receiver Frame

3

Use hand to pull out R-HDD

4

Use Key 1390-1375, to unlock HDD by Turning Clock Wise

1

Pull Out

1 2 3 4

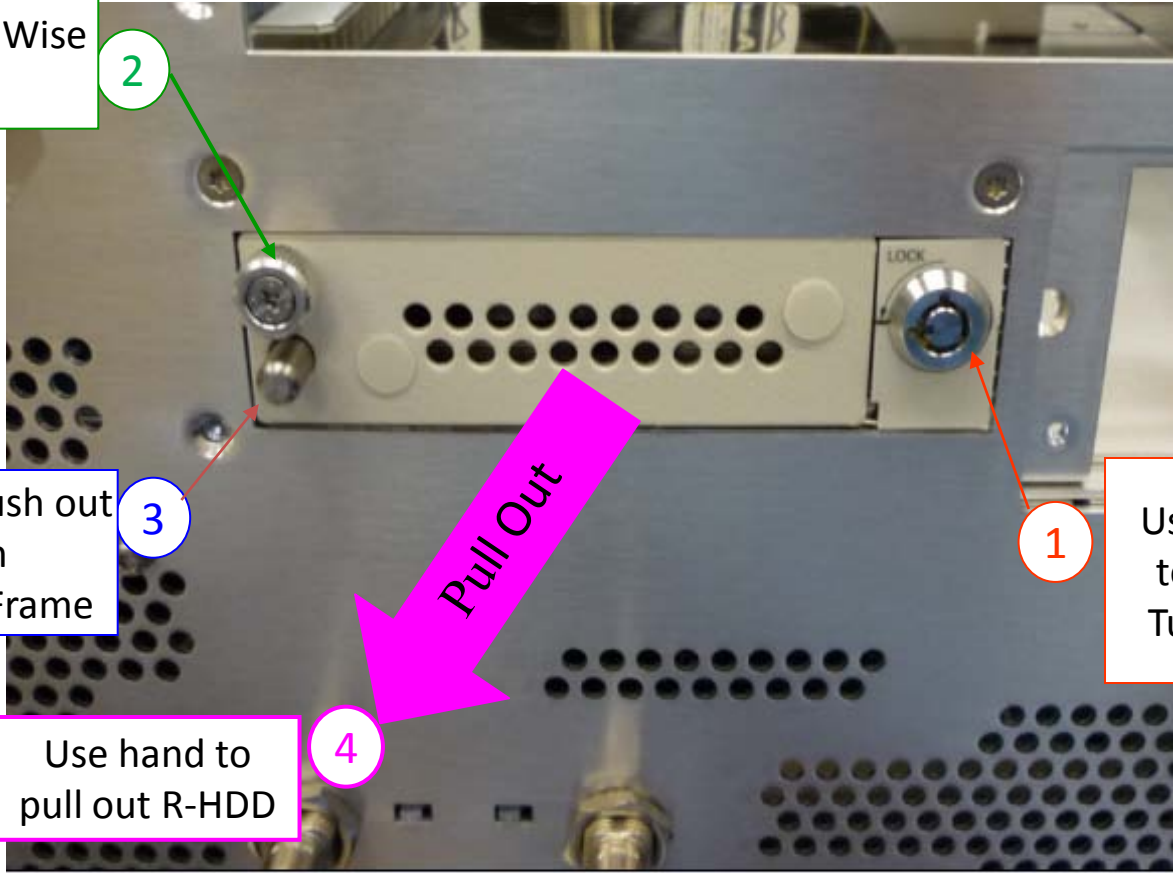

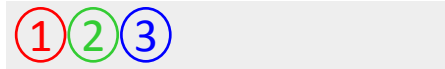
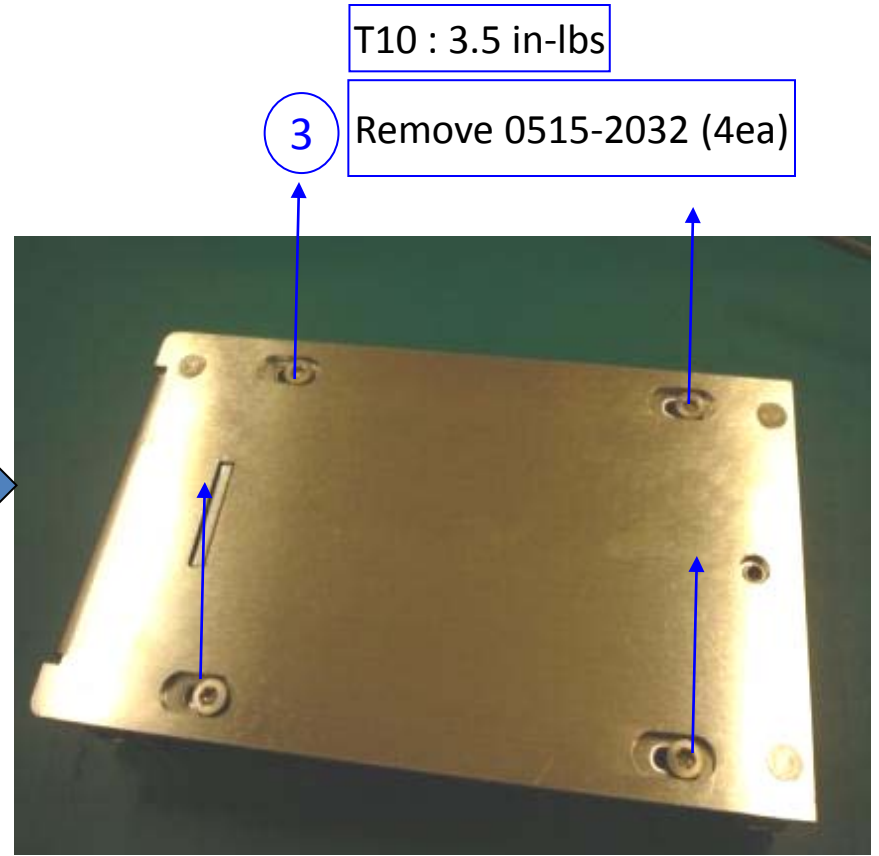
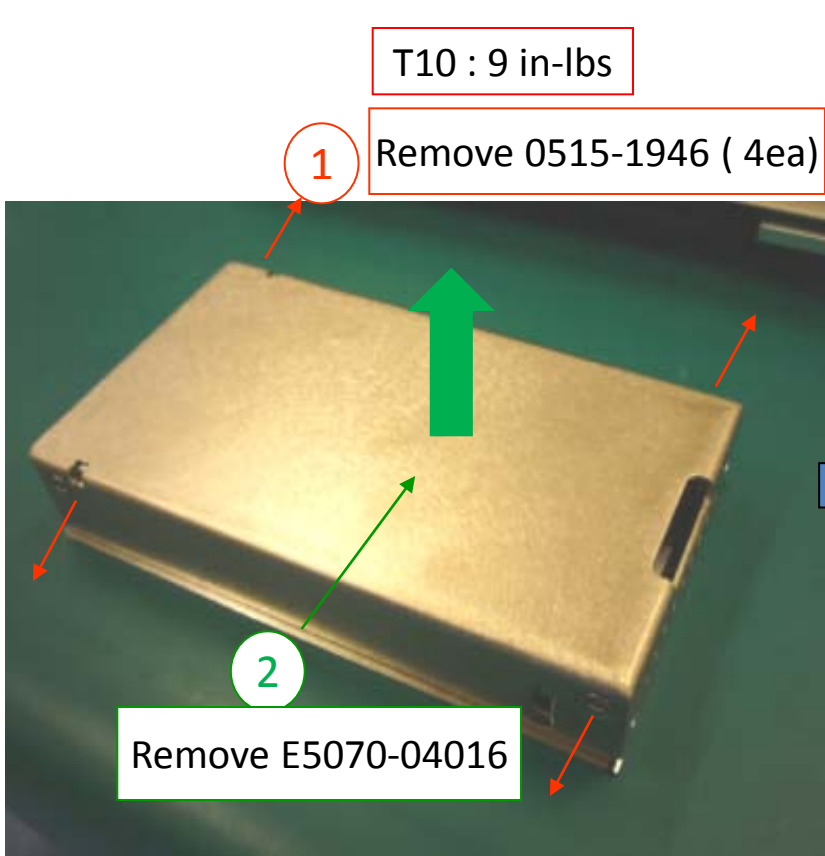

1

Remove HDD, **0950-5263**
from **E5070-00666**



Remove **E5070-66648**
from HDD, **0950-5263**

2



1 2 3 4

Standard Hard Disk Dis-Assembly Procedure (For Option 019 only)

Note:

1. Torque value shown in this document is only for reference and only used during assembly.

1
Disconnect Flat cable, E5072-61624
from CPU Motherboard



2
Disconnect USB cable, E5061-61652
& power supply cable, E5072-61621

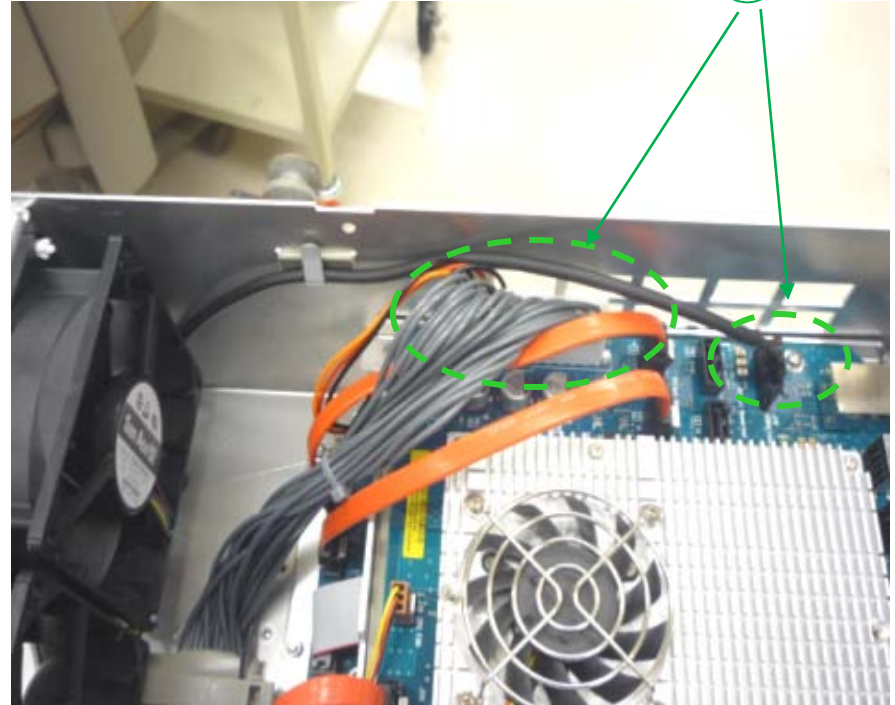

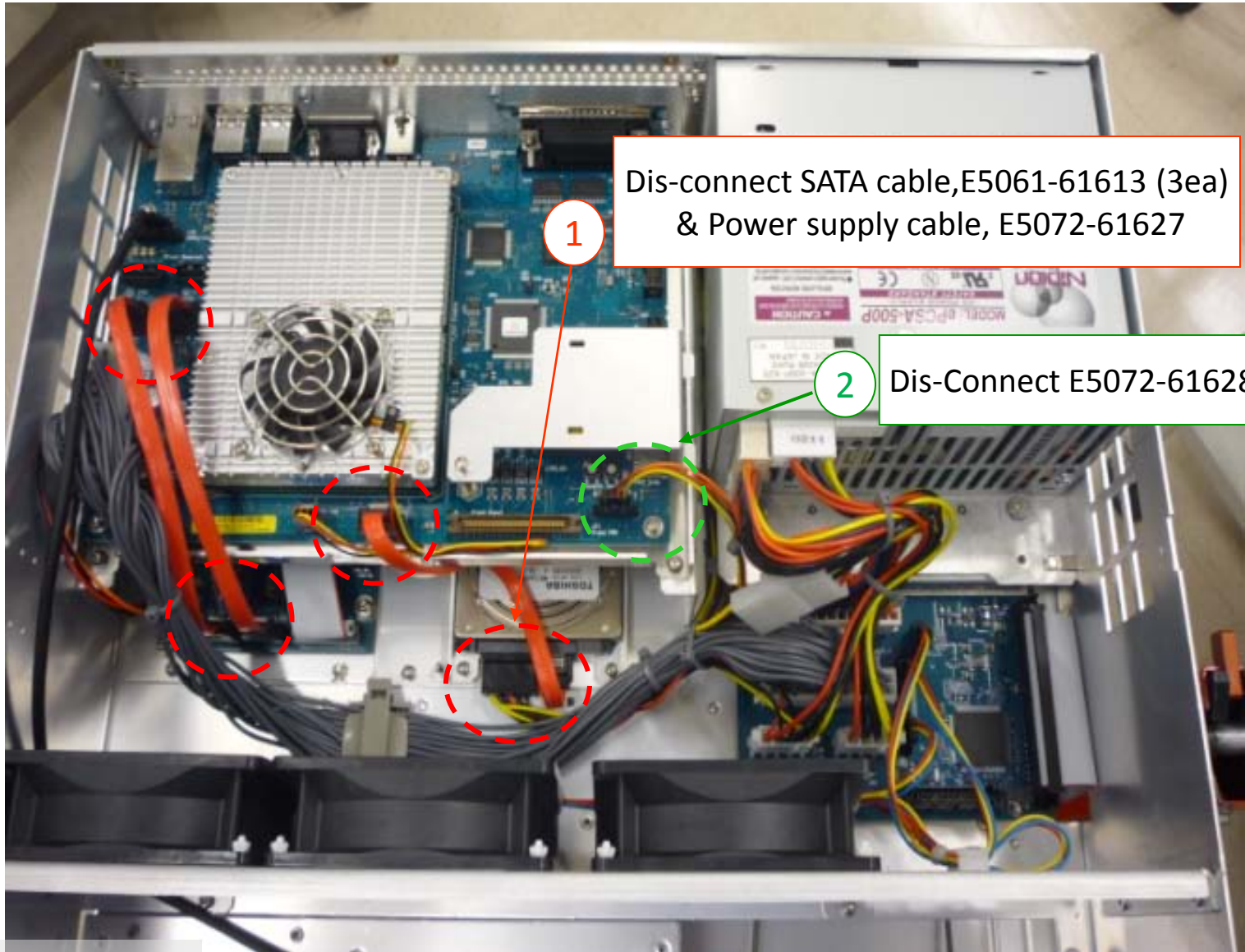

Dis-connect SATA cable, E5061-61613 (3ea)
& Power supply cable, E5072-61627

Dis-Connect E5072-61628

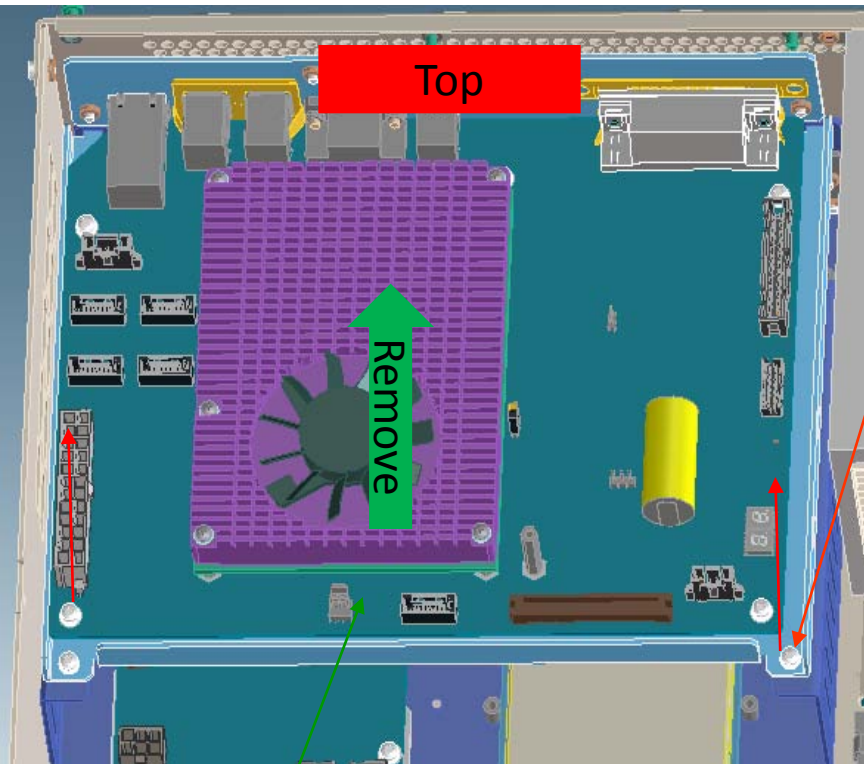

2 Remove E5072-62050,
CPU Module Assembly

1

T10 : 9 in-lbs
Remove 0515-0430 (6 ea)

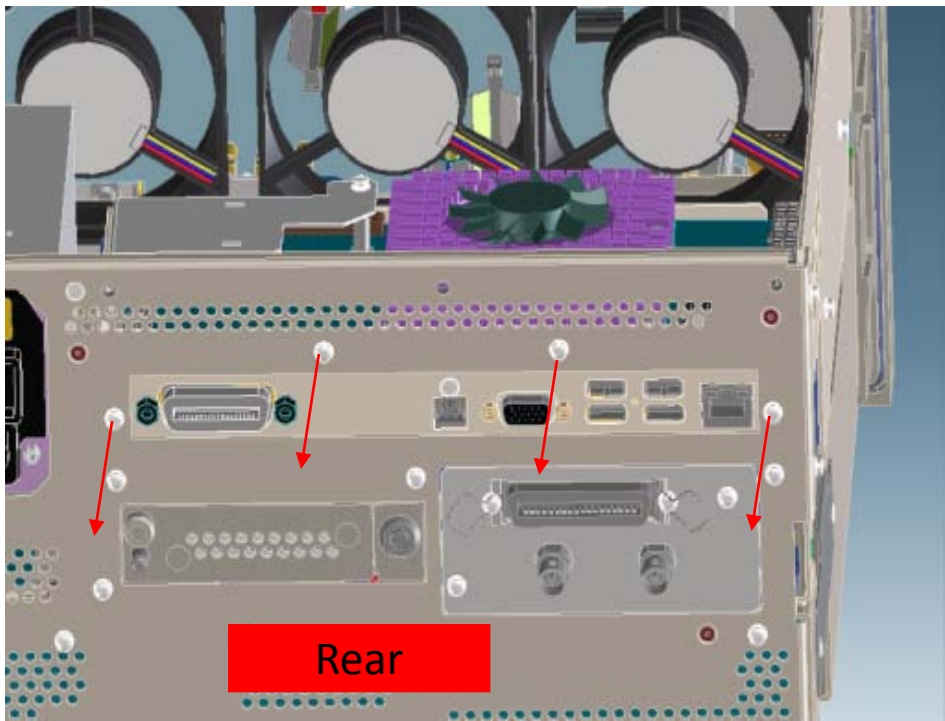

1 2

Remove HDD Assembly's Holder

2

Remove

T10 : 9 in-lbs

1

Remove 0515-0430 (2ea)

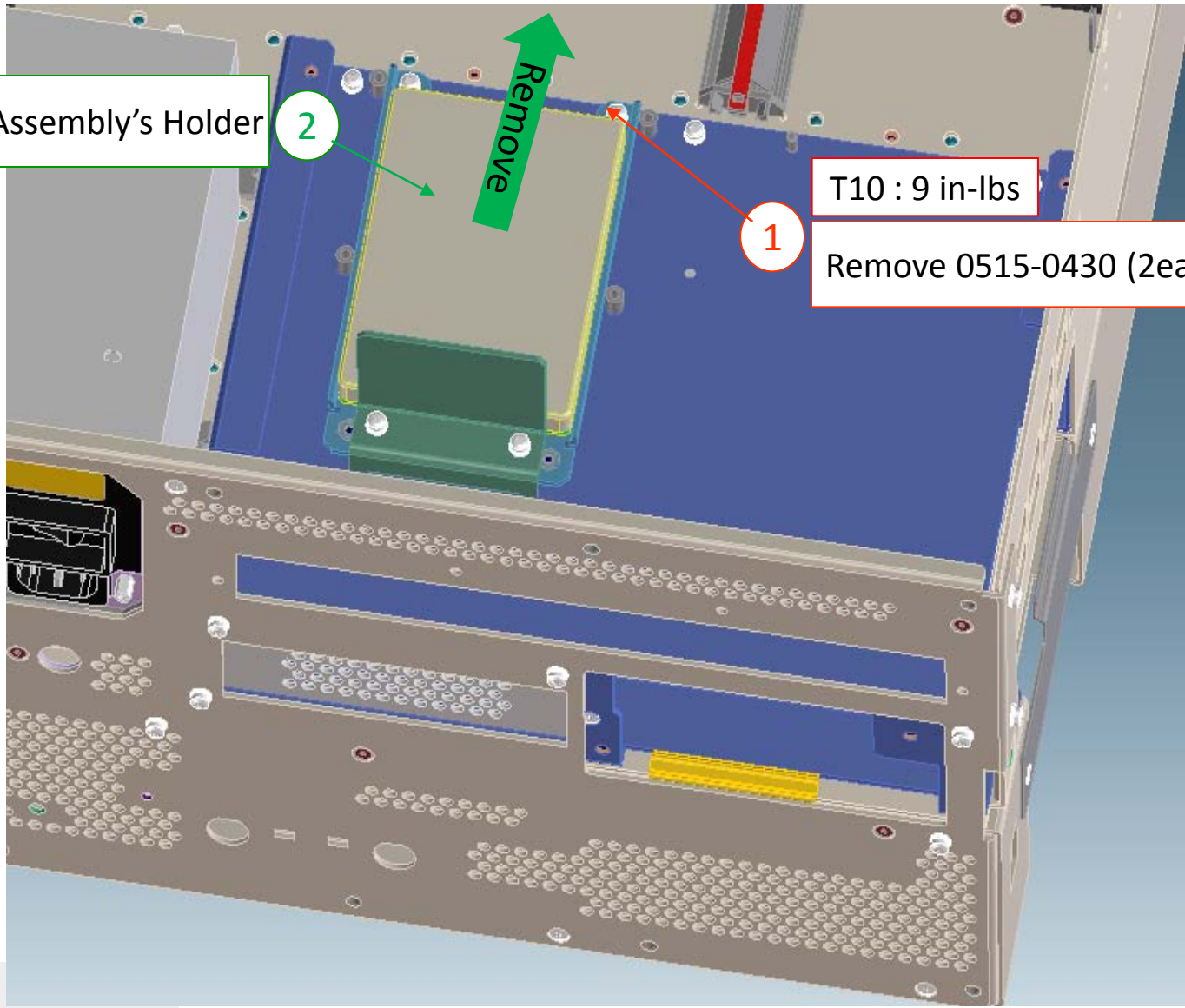

1 2

T10 : 3.5 in-lbs

1

Remove 0515-2146 (4ea)

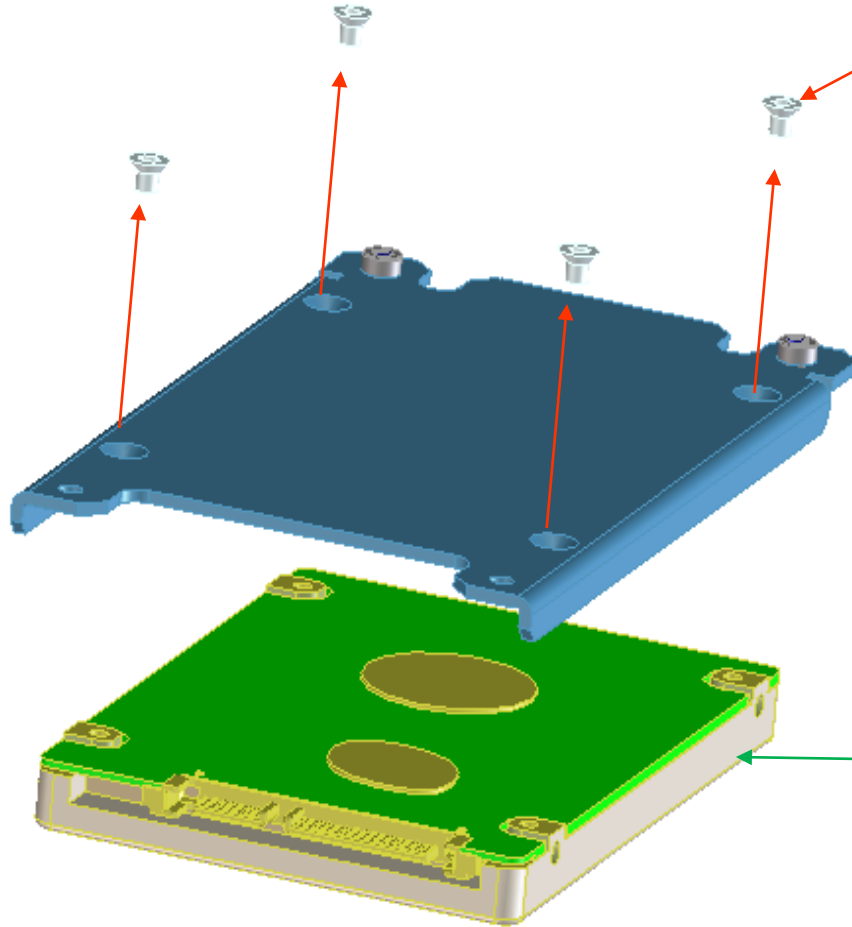

2

Remove HDD, 0950-5263

1 2

A50 CPU Module (E5072-62050)

Dis-Assembly Procedure

Note:

1. Torque value shown in this document is only for reference and only used during assembly.

1
Disconnect Flat cable, E5072-61624
from CPU Motherboard

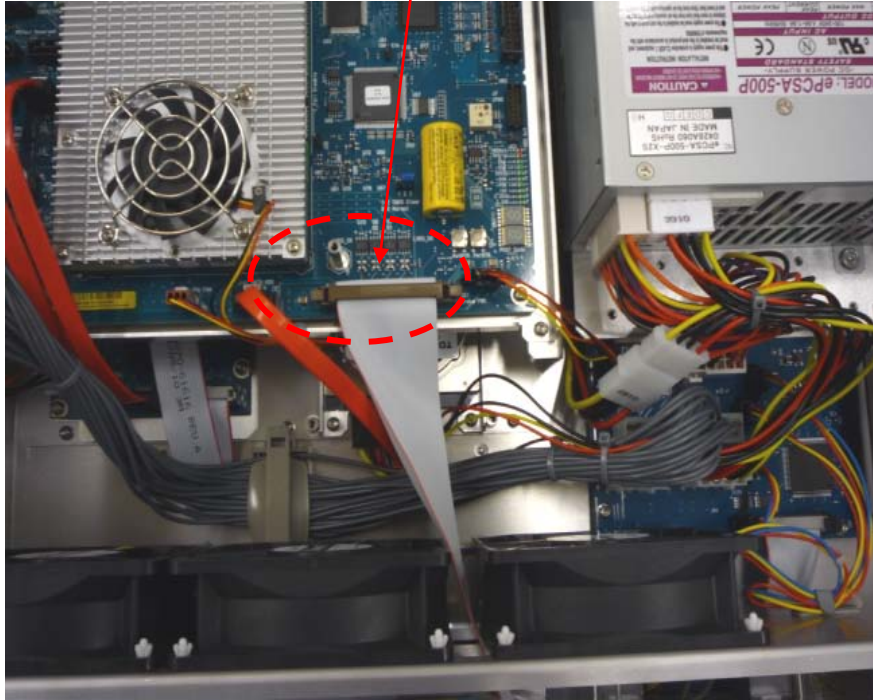

2
Disconnect USB cable, E5061-61652
& power supply cable, E5072-61621

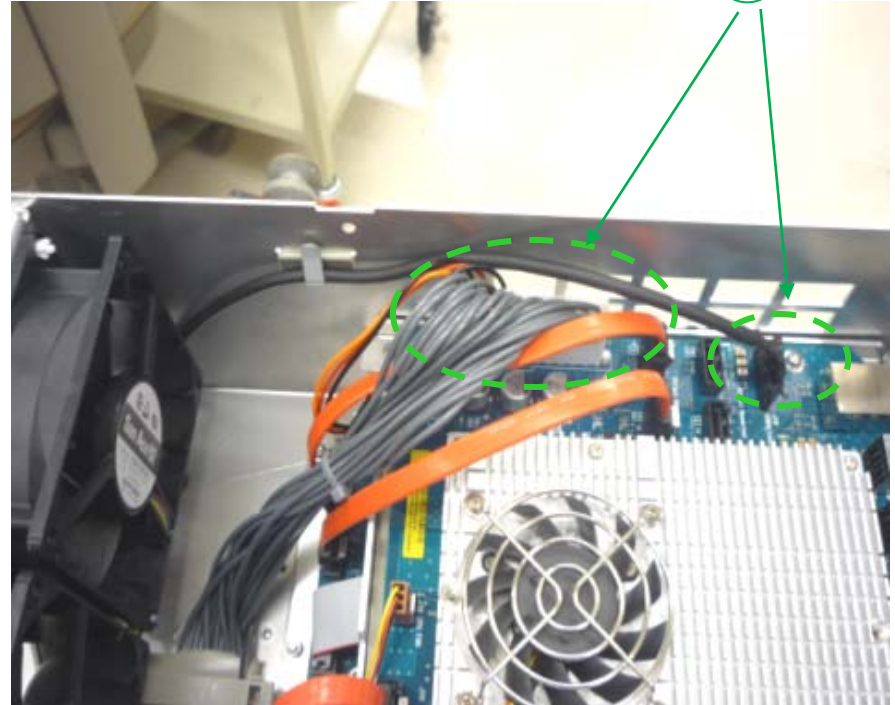

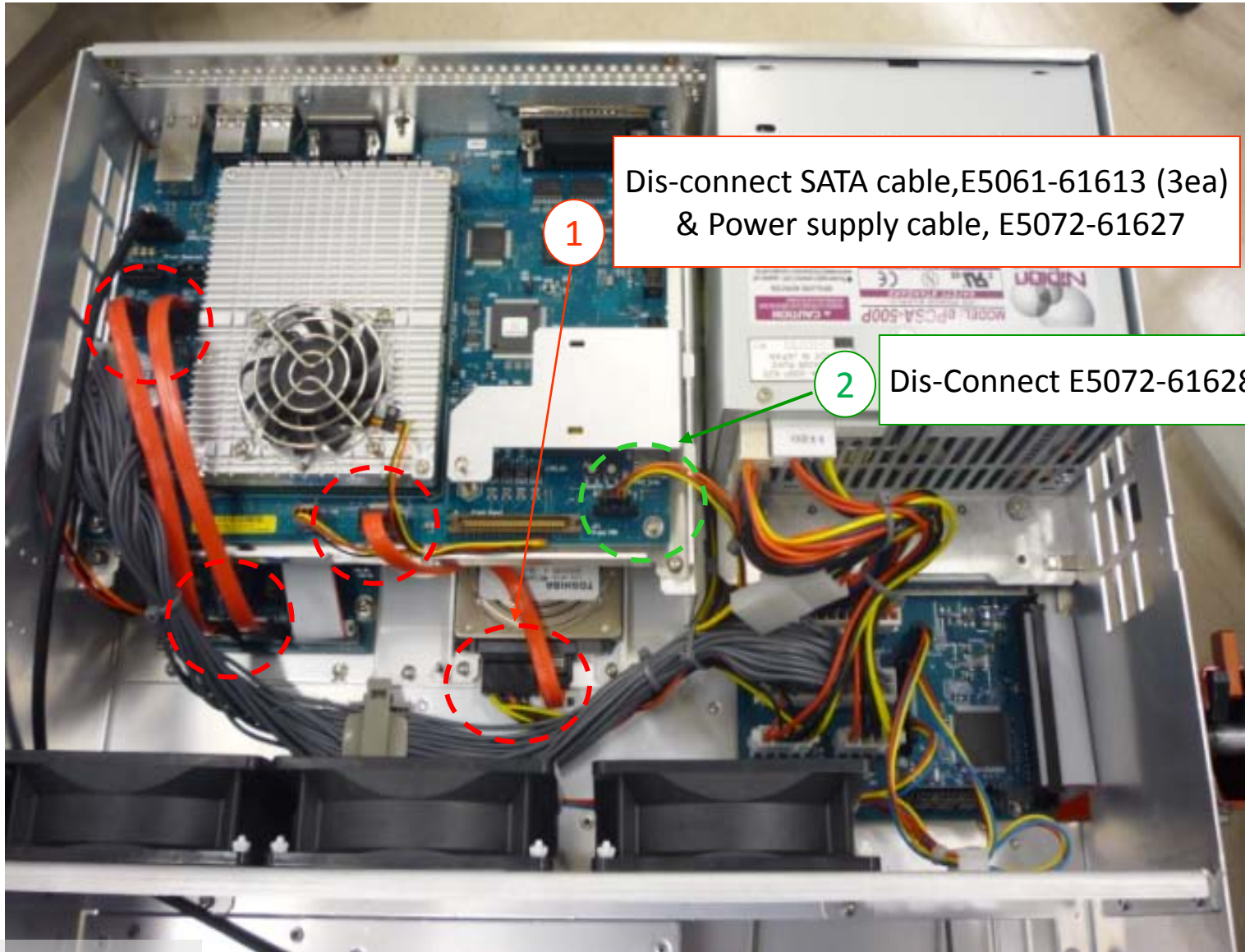

Dis-connect SATA cable, E5061-61613 (3ea)
& Power supply cable, E5072-61627

Dis-Connect E5072-61628

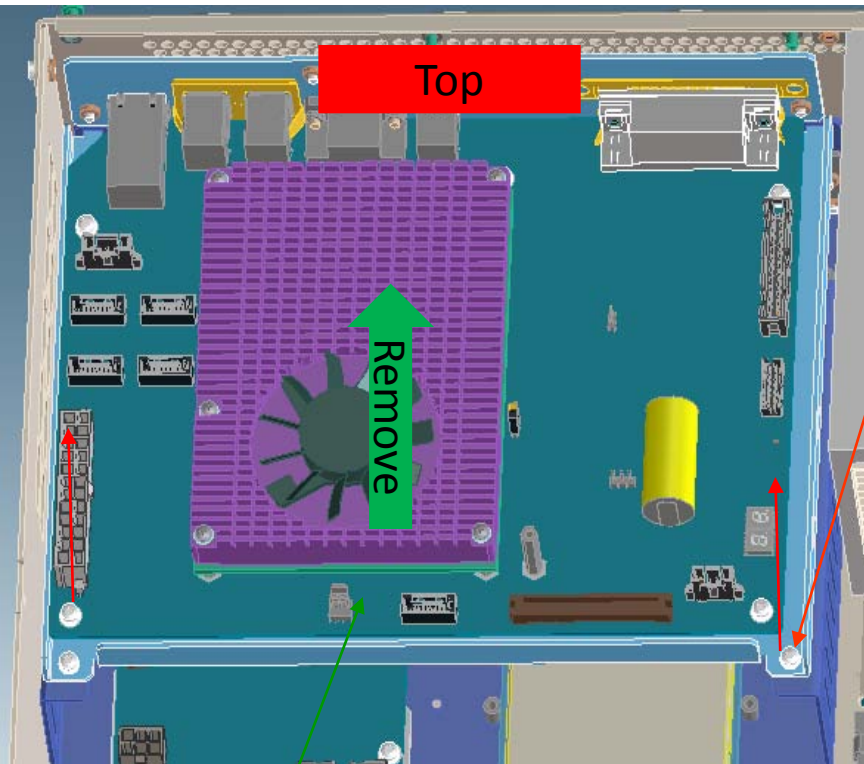

2 Remove E5072-62050,
CPU Module Assembly

1

T10 : 9 in-lbs
Remove 0515-0430 (6 ea)

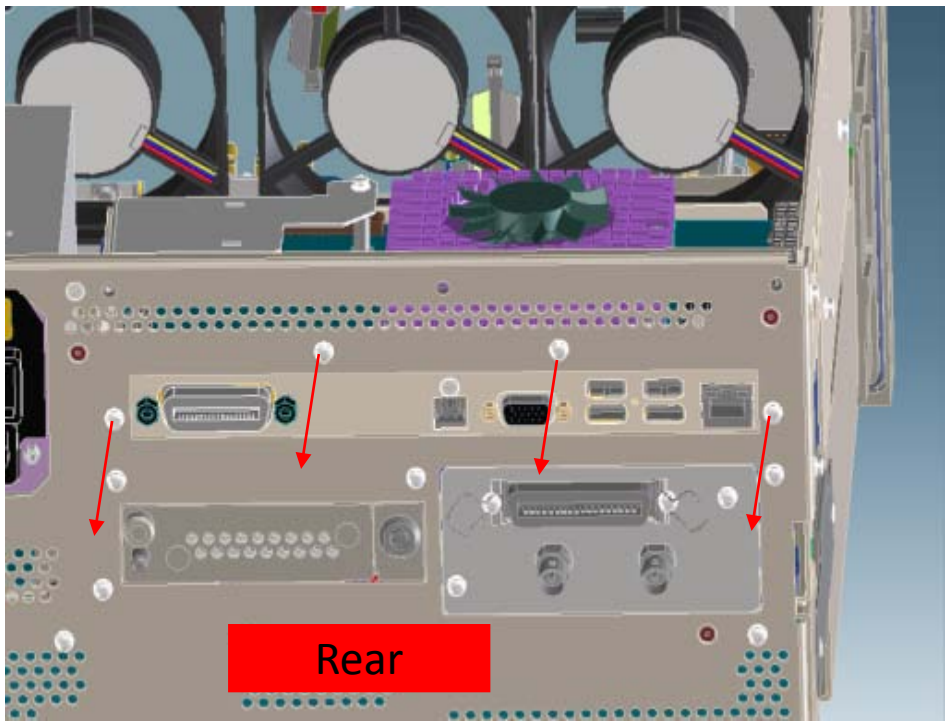

1 2

Oven (E5071-66605)
Dis-Assembly Procedure
(For Option 1E5 Only)

Note:

1. Torque value shown in this document is only for reference and only used during assembly.

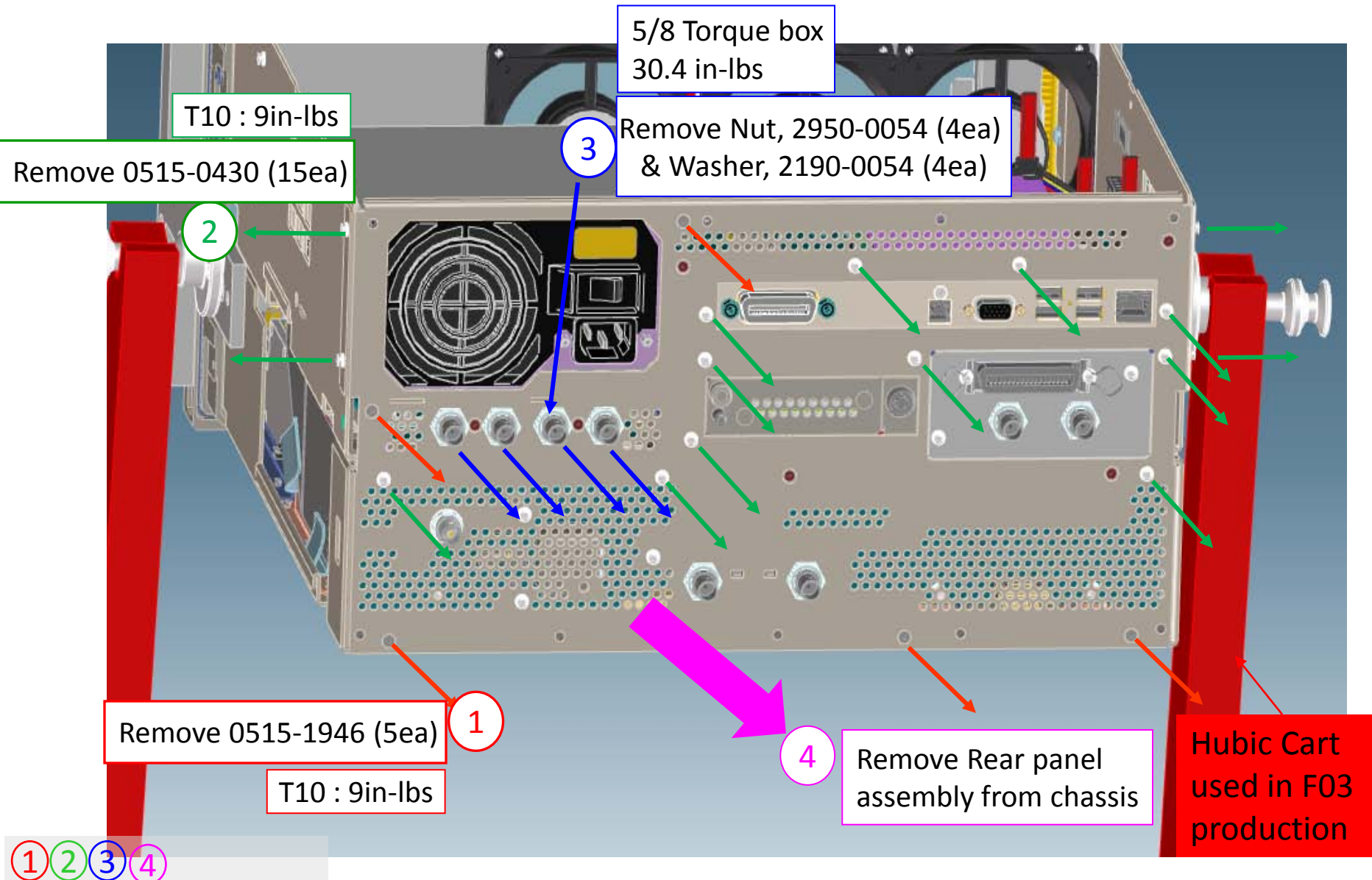

5/8 Torque box
30.4 in-lbs

T10 : 9in-lbs

Remove 0515-0430 (15ea)

Remove Nut, 2950-0054 (4ea)
& Washer, 2190-0054 (4ea)

Remove 0515-1946 (5ea)

T10 : 9in-lbs

Remove Rear panel
assembly from chassis

Hubic Cart
used in F03
production

- 1
- 2
- 3
- 4

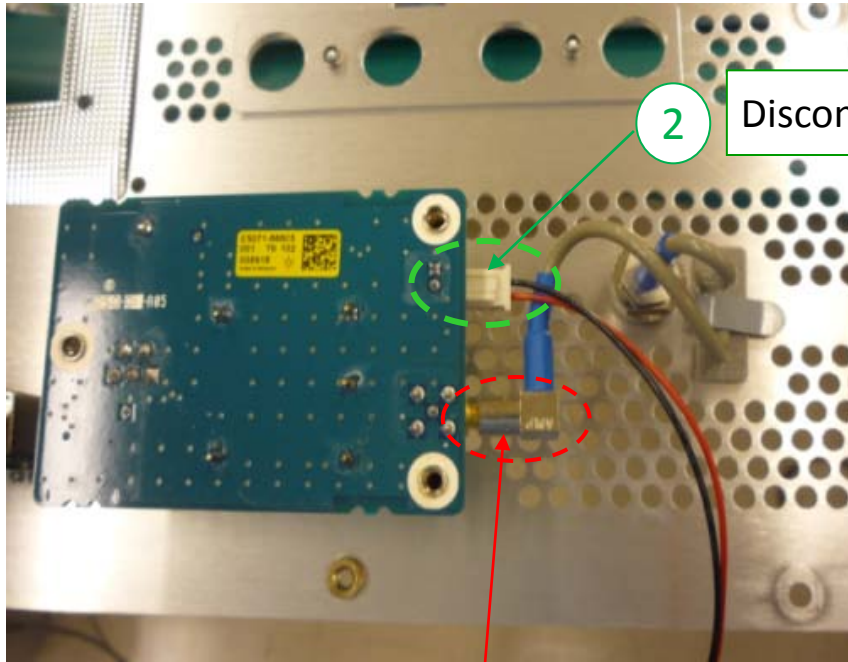

2 Disconnect E5071-61602

1 Disconnect 43521-61622

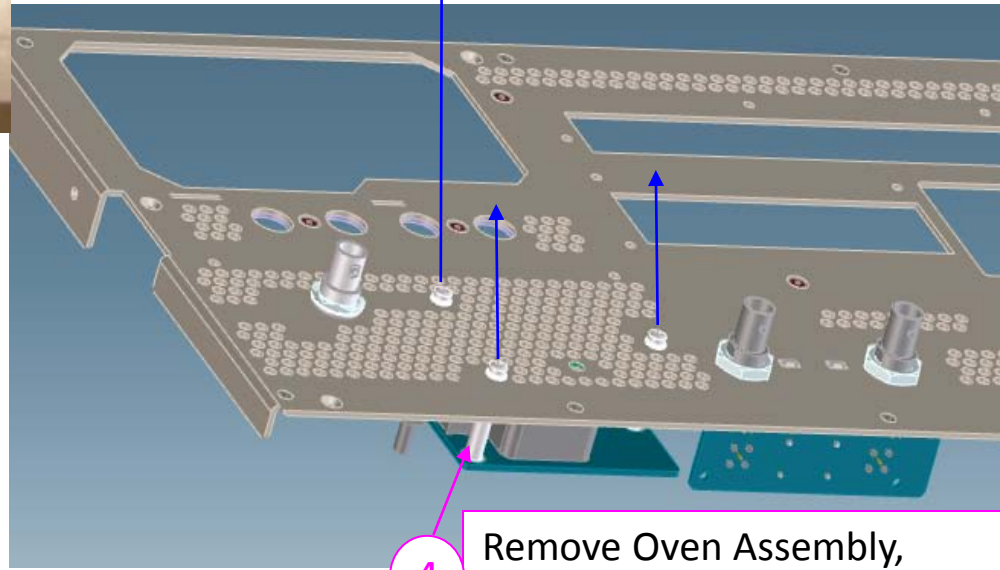

T10 : 9 in-lbs

3 Remove 0515-0430 (3ea)

4 Remove Oven Assembly, E5071-66605 from rear panel

- 1
- 2
- 3
- 4

A61, DSP Board (E5070-66661)

Dis-Assembly Procedure

Note:

1. Torque value shown in this document is only for reference and only used during assembly.

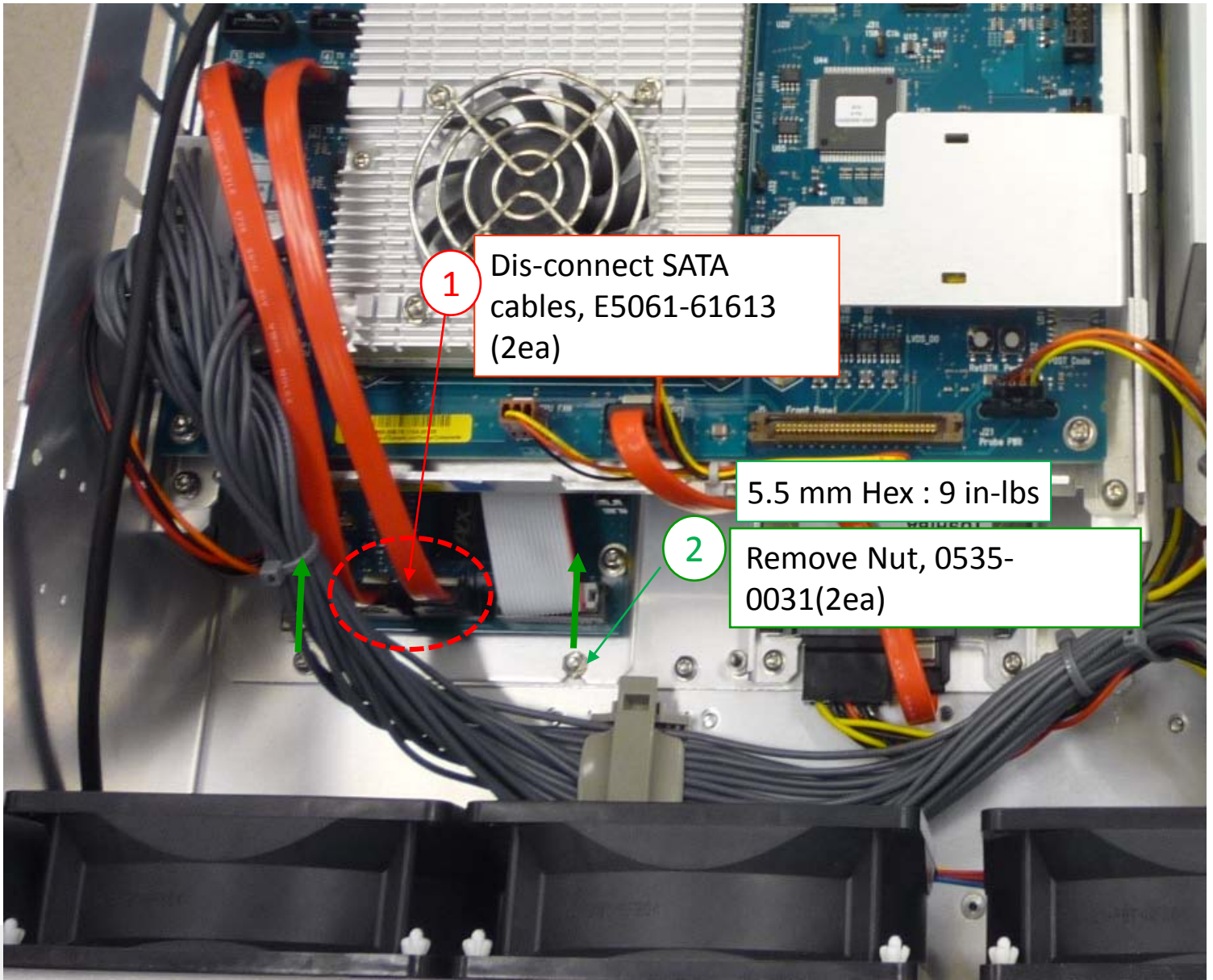

1 Dis-connect SATA cables, E5061-61613 (2ea)

5.5 mm Hex : 9 in-lbs

2 Remove Nut, 0535-0031(2ea)

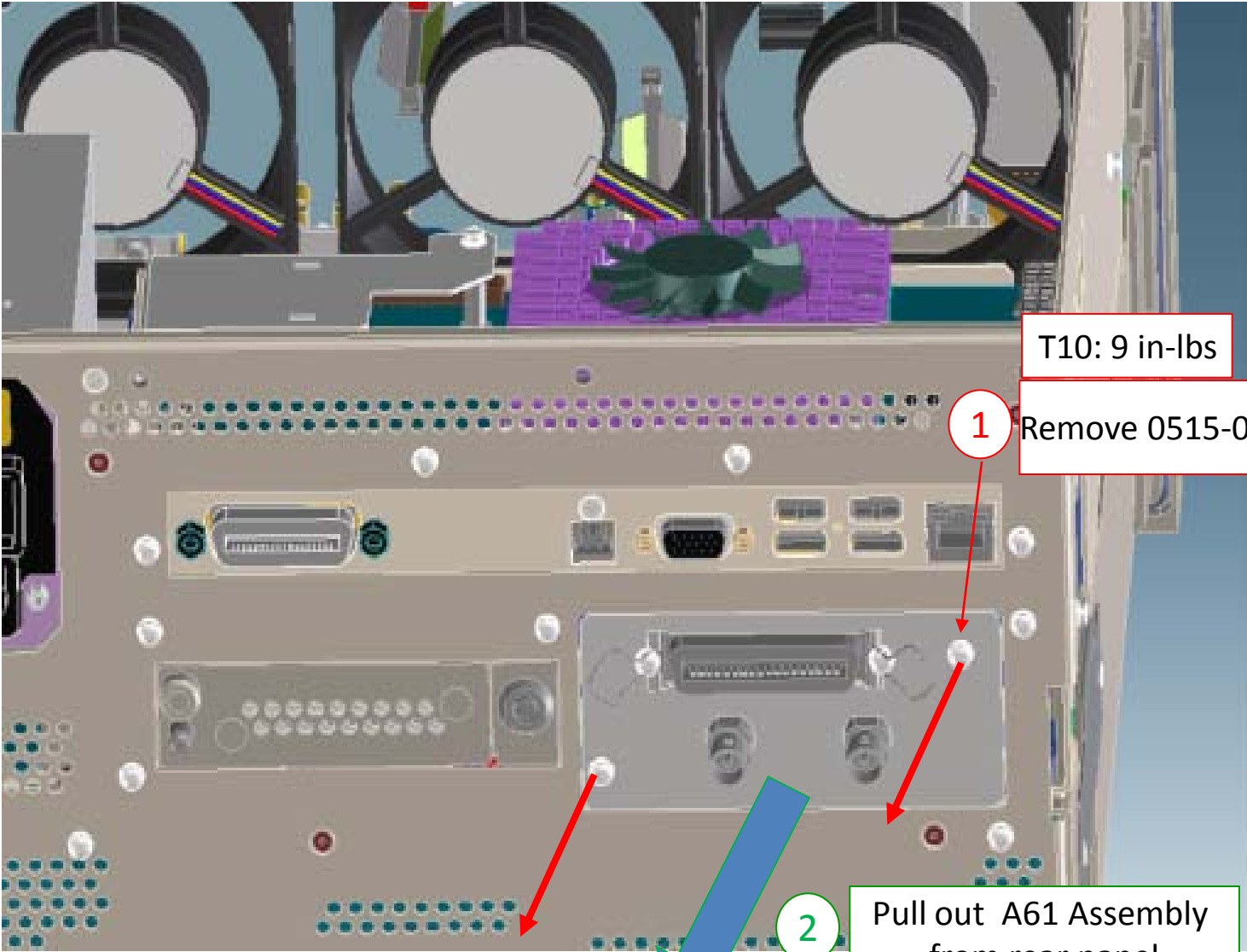

T10: 9 in-lbs

1 Remove 0515-0430 (2ea)

2 Pull out A61 Assembly from rear panel

1 2

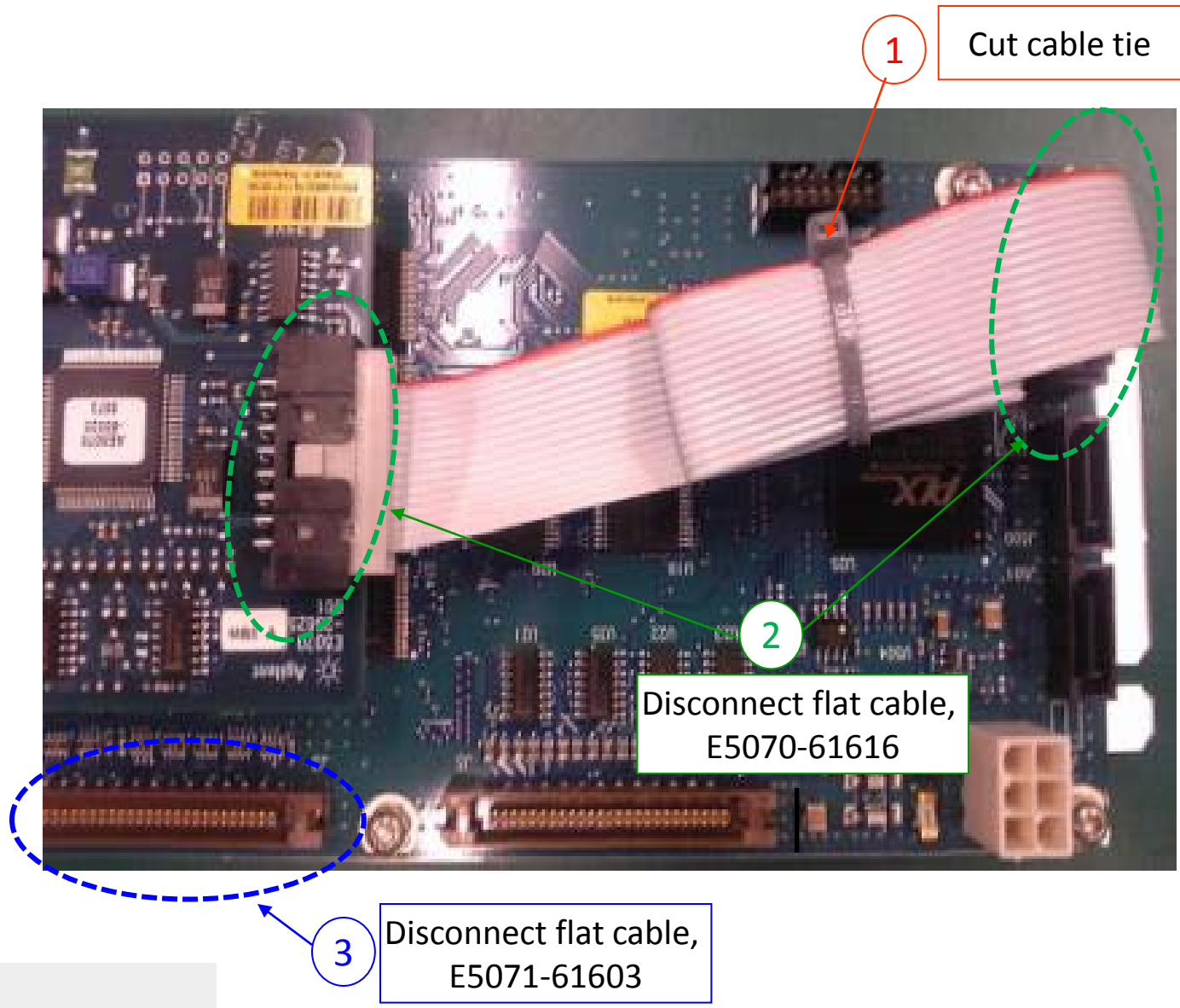

1

Cut cable tie

2

Disconnect flat cable,
E5070-61616

3

Disconnect flat cable,
E5071-61603

1 2 3

5/8 Torque box
30.4 in-lbs

Remove Nut, 2950-0054 (2ea)
& Washer, 2190-0054 (2ea)

Remove A61 Board from
bracket, E5072-00205

2

1

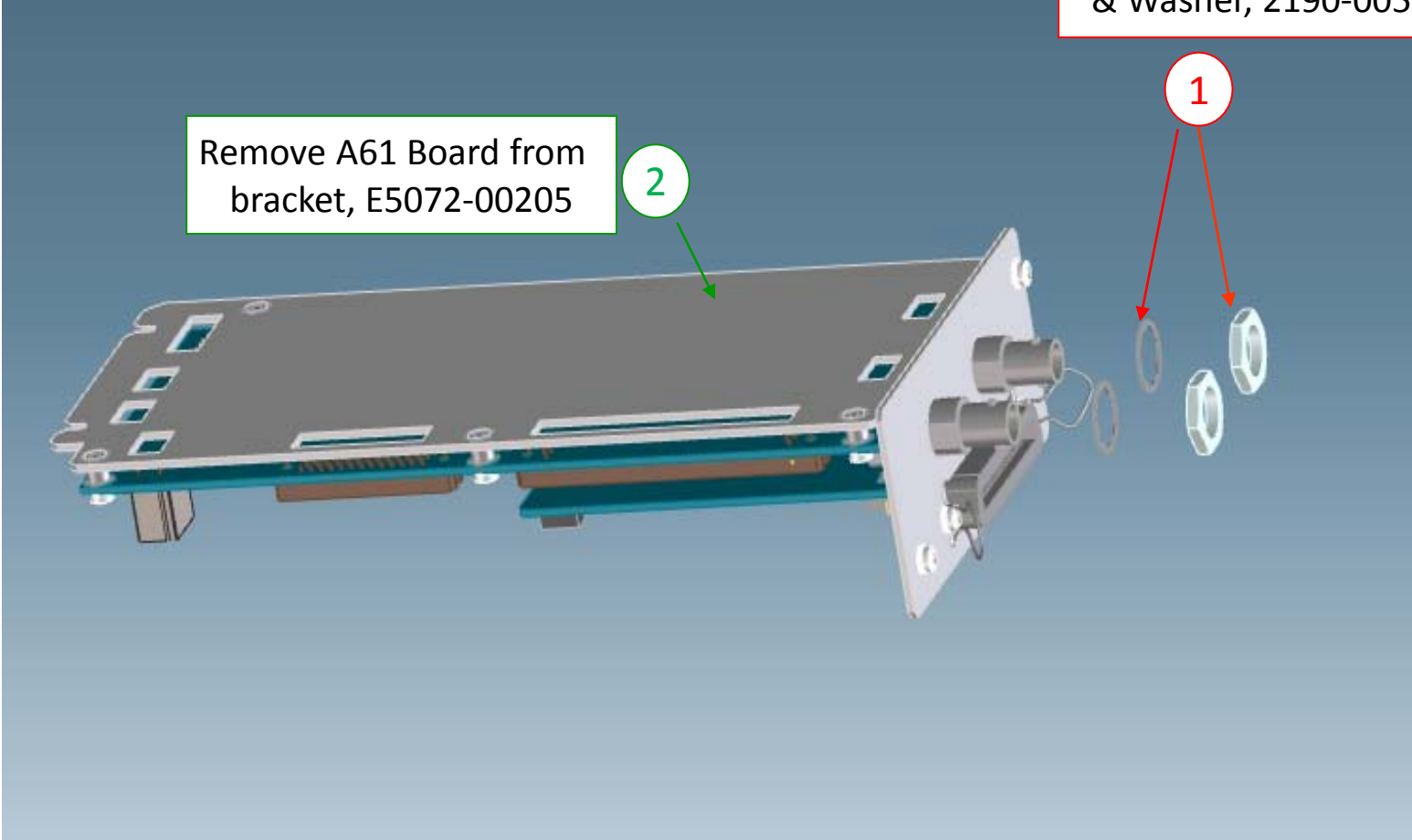

1 2

T10 : 9 in-lbs

1 Remove 0515-0430 (4ea)

Remove A61 Board, E5070-66661

2

1

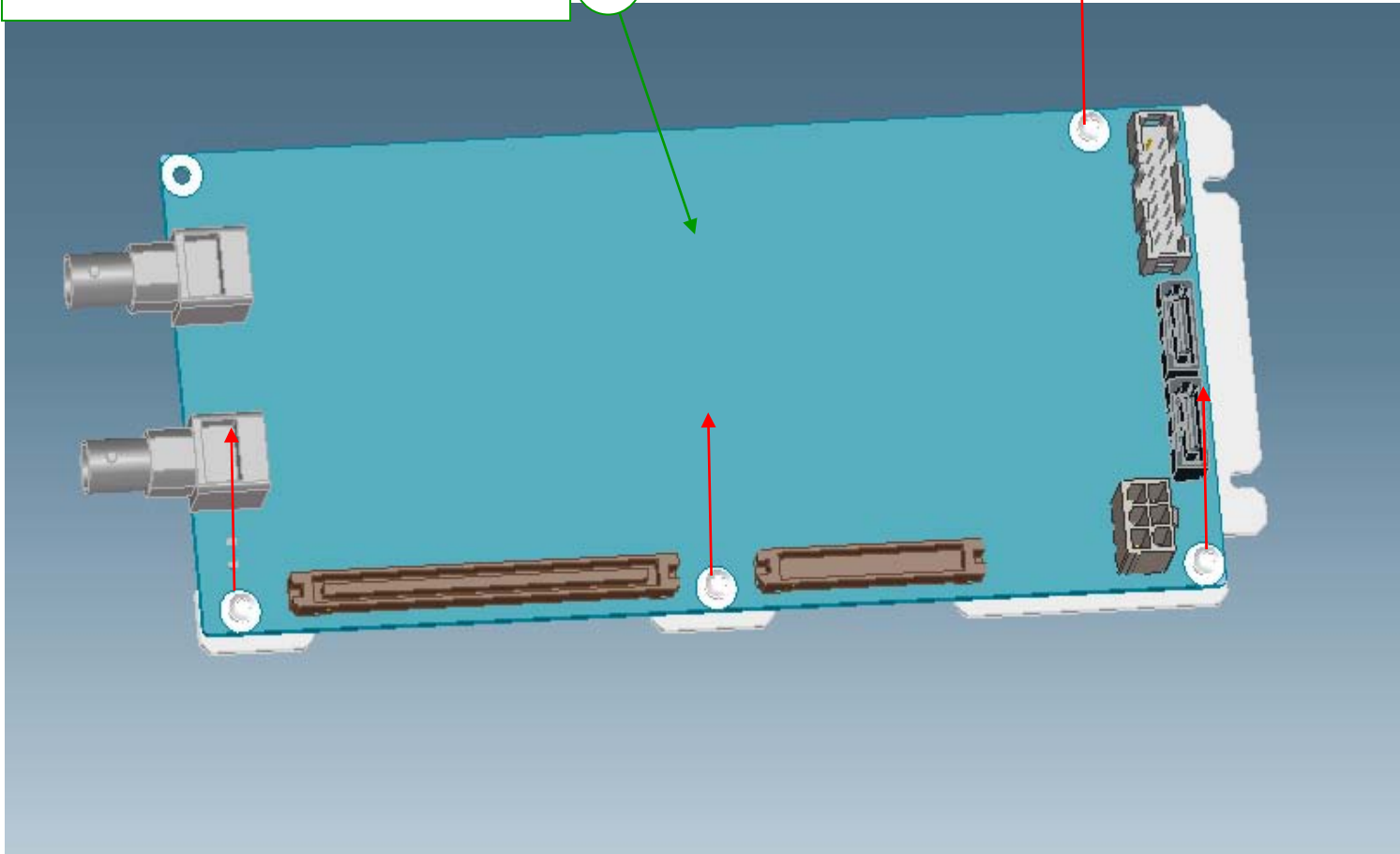

1 2

A80, Analog Base Module (E5072-61080)

Dis-Assembly Procedure

Note:

1. Torque value shown in this document is only for reference and only used during assembly.

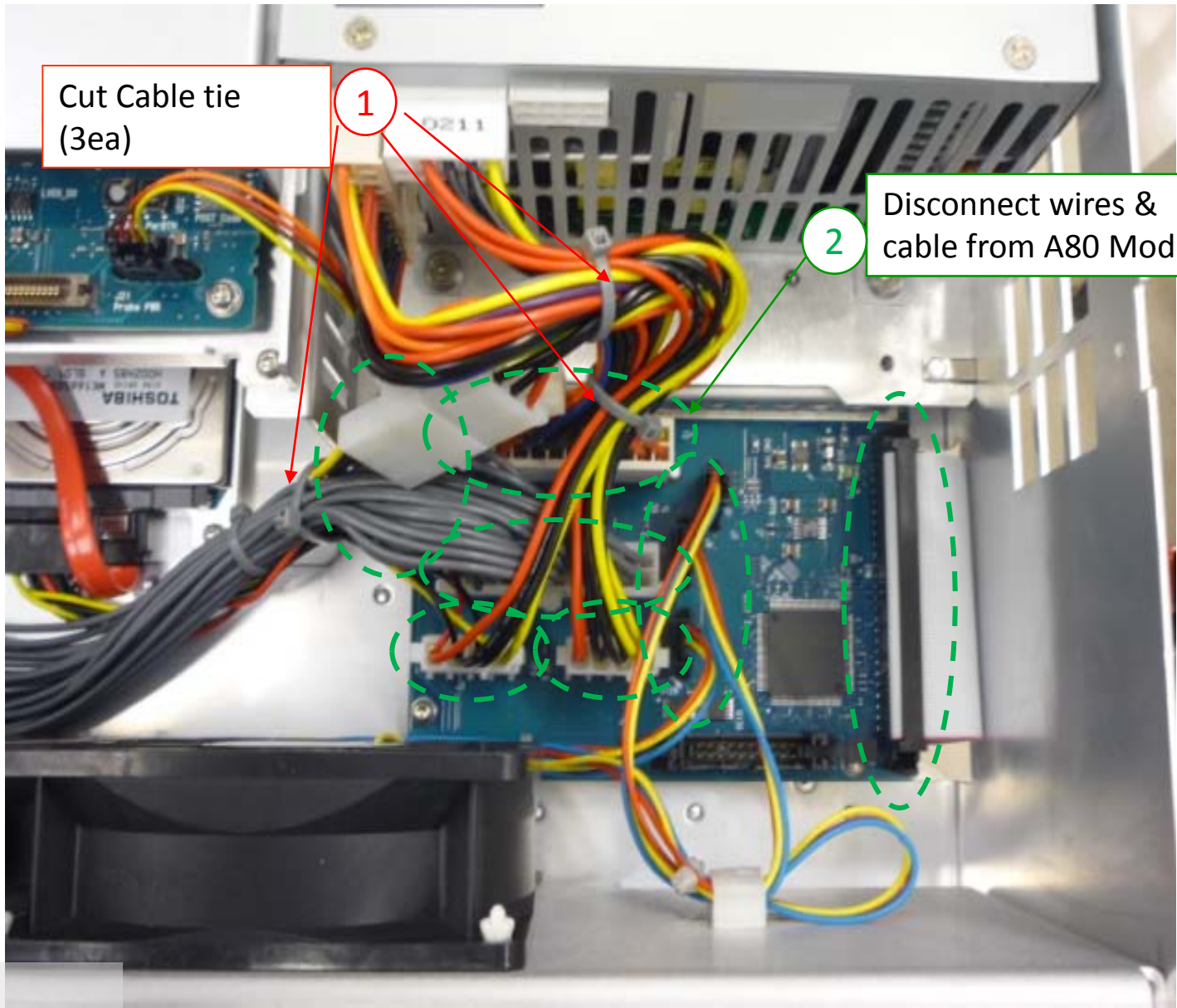

Cut Cable tie
(3ea)

1

Disconnect wires &
cable from A80 Module

2

1 2

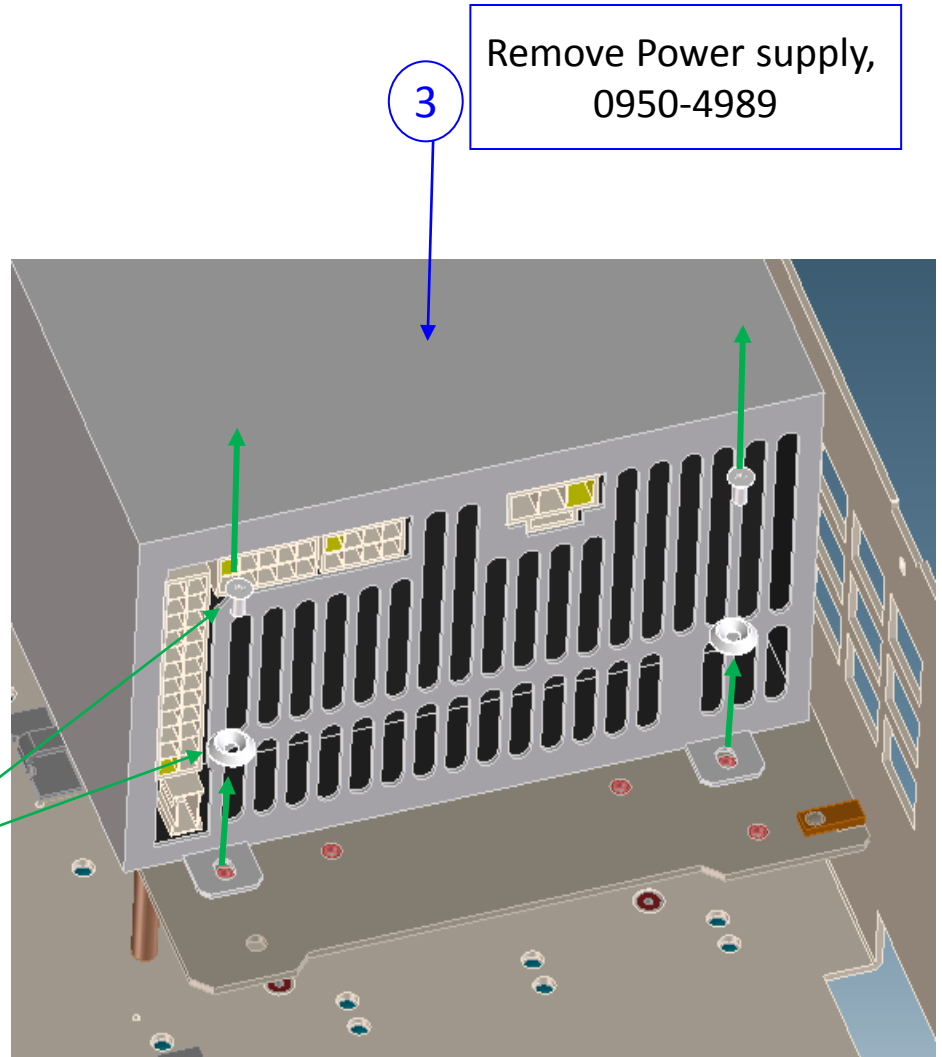
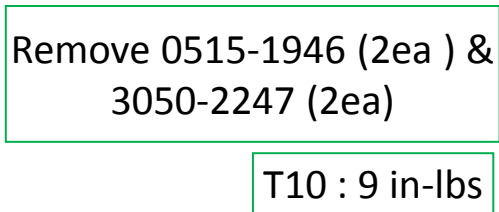
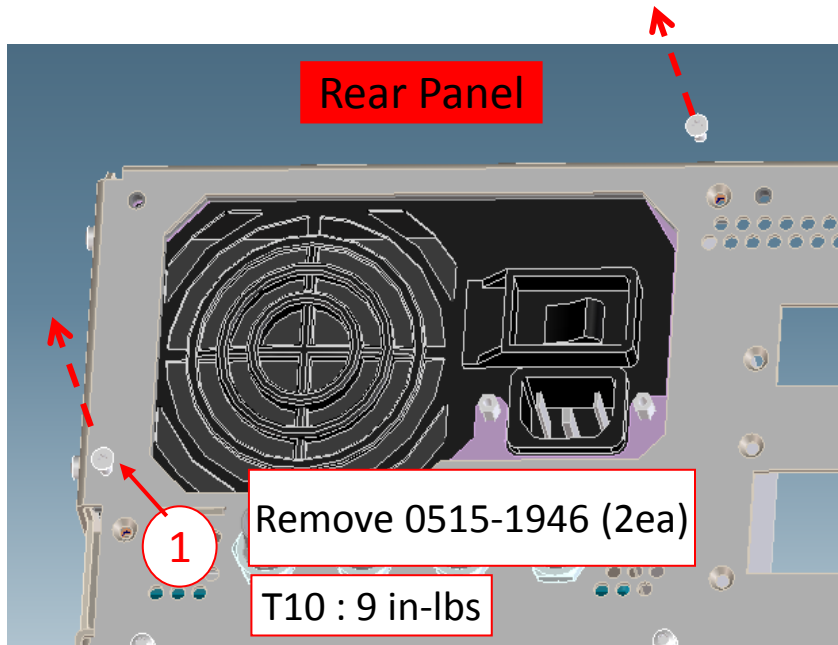

T10 : 9 in-lbs

1 Remove 0515-1946 (2ea)

2 Remove E5071-00612

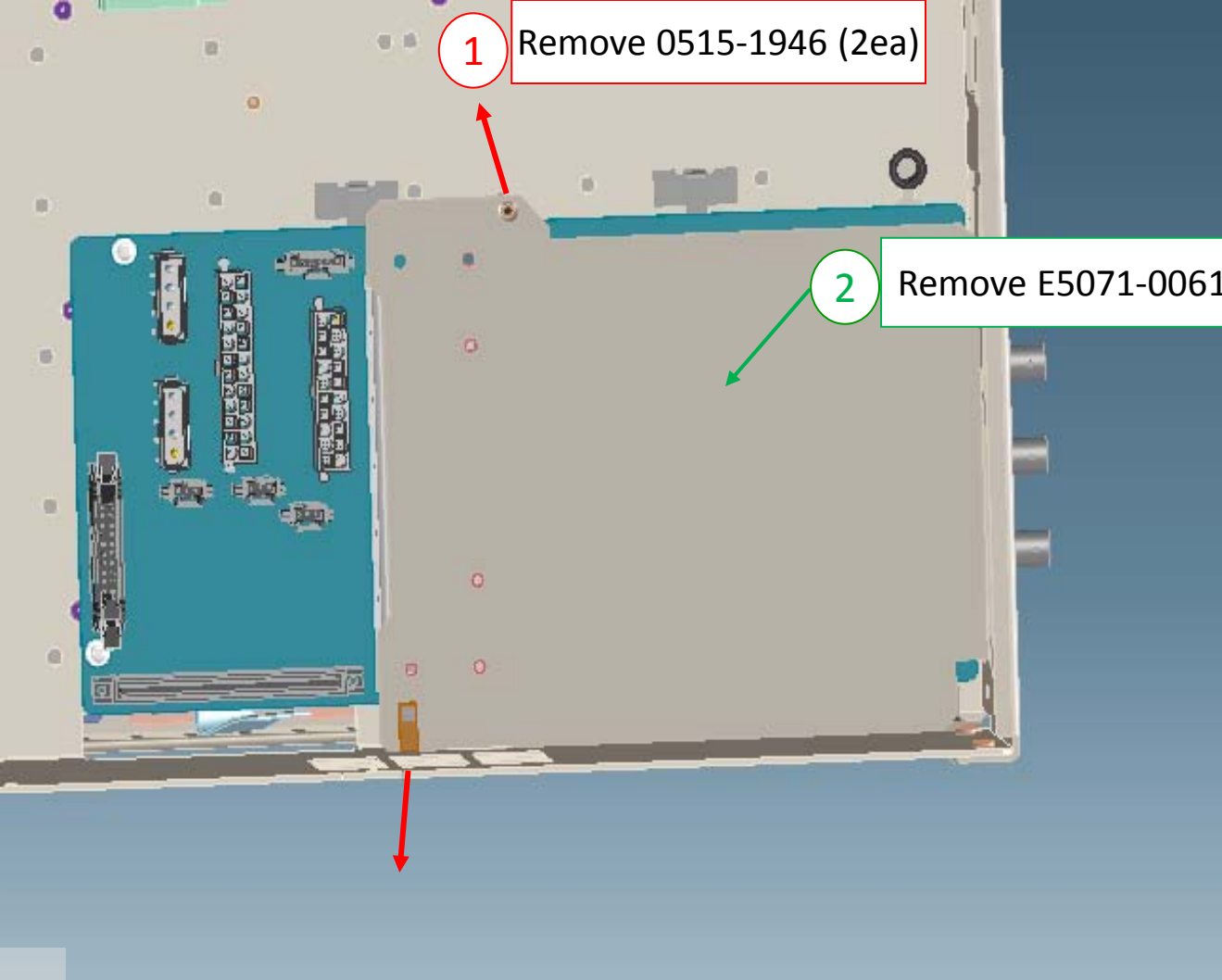

1 2

T10 : 9 in-lbs

1 Remove 0515-0430 (3ea)

3 Remove E5072-61080 from chassis

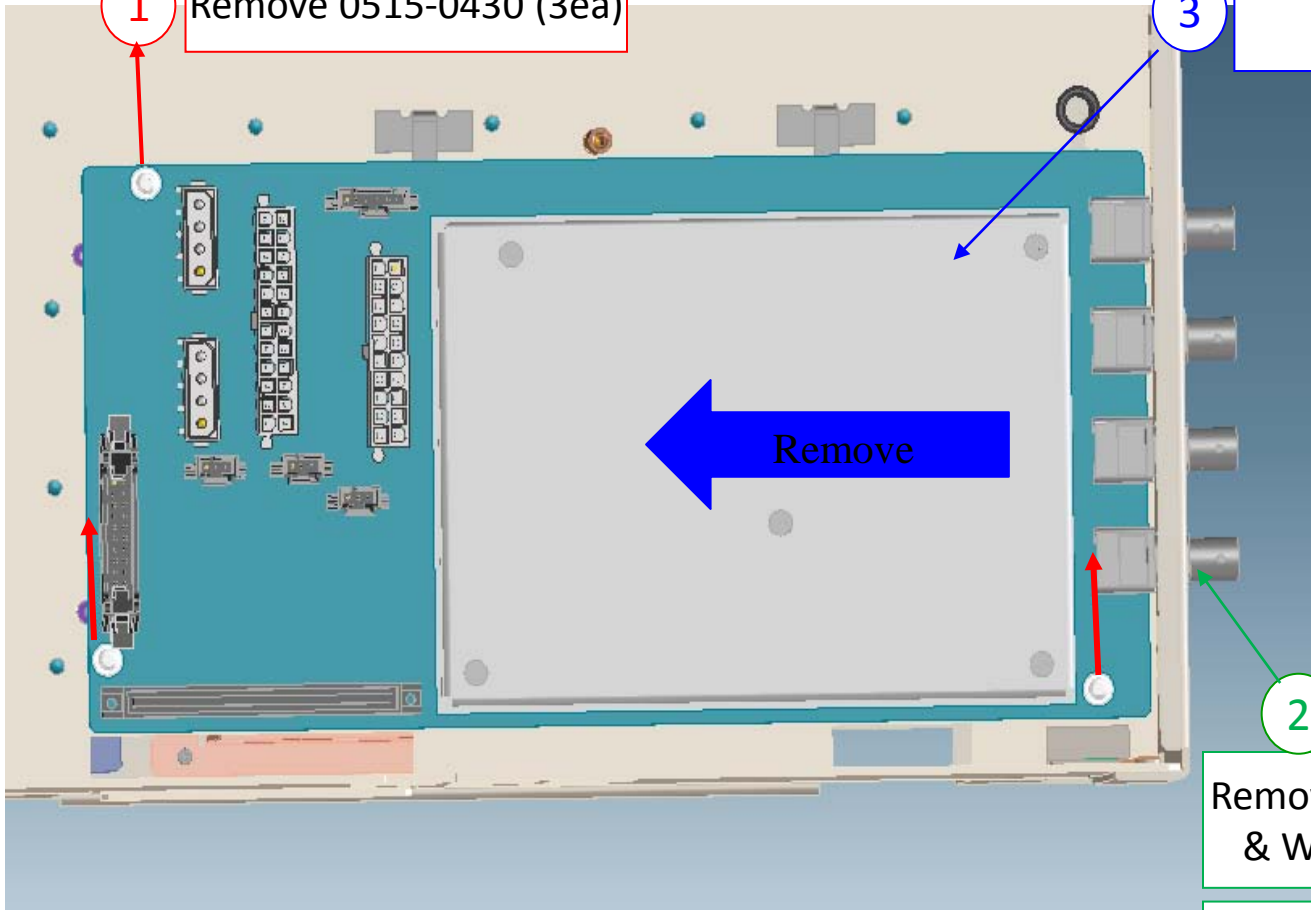

2 Remove Nut, 2950-0054 (4ea) & Washer 2190-0054 (4ea)

5/8 Torque box
30.4 in-lbs

1 2 3

LEVEL VERNIER MODULE, A82 (E5071-62183),
SYNTHESIZER MODULE, A91 (E5071-62191),
RECEIVER MODULE, A2 (E5072-62002),
LOCAL DISTRIBUTOR, A84 (E5072-61084)

Dis-Assembly Procedure

Note:

1. Torque value shown in this document is only for reference and only used during assembly.

1 Remove 5041-9176

8mm Open End :
9.5 in-lbs

Remove E8356-20072 (6 ea) 3

Remove N5242-00030 2

Hubic Cart
used in F03
production

1 2 3

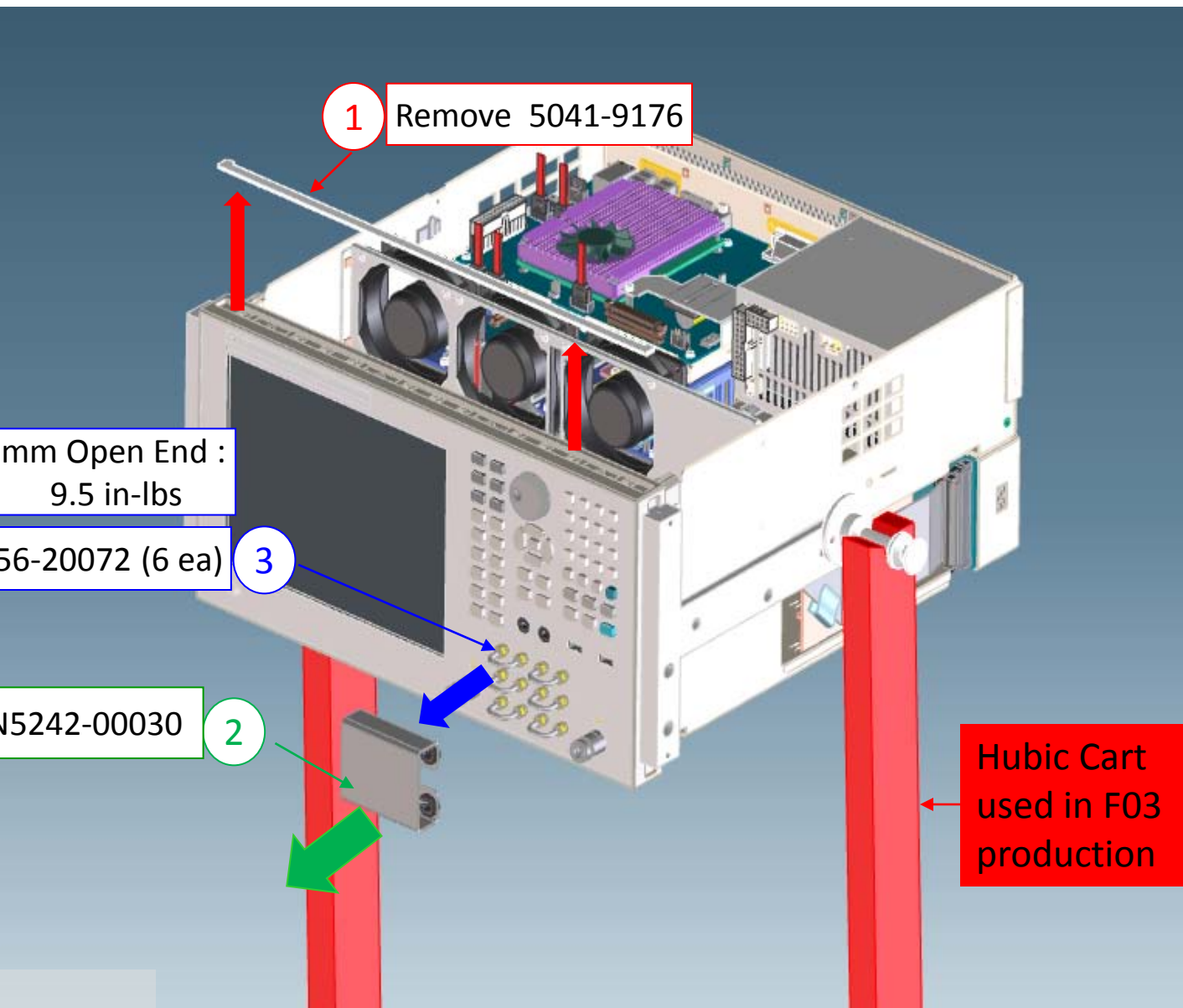

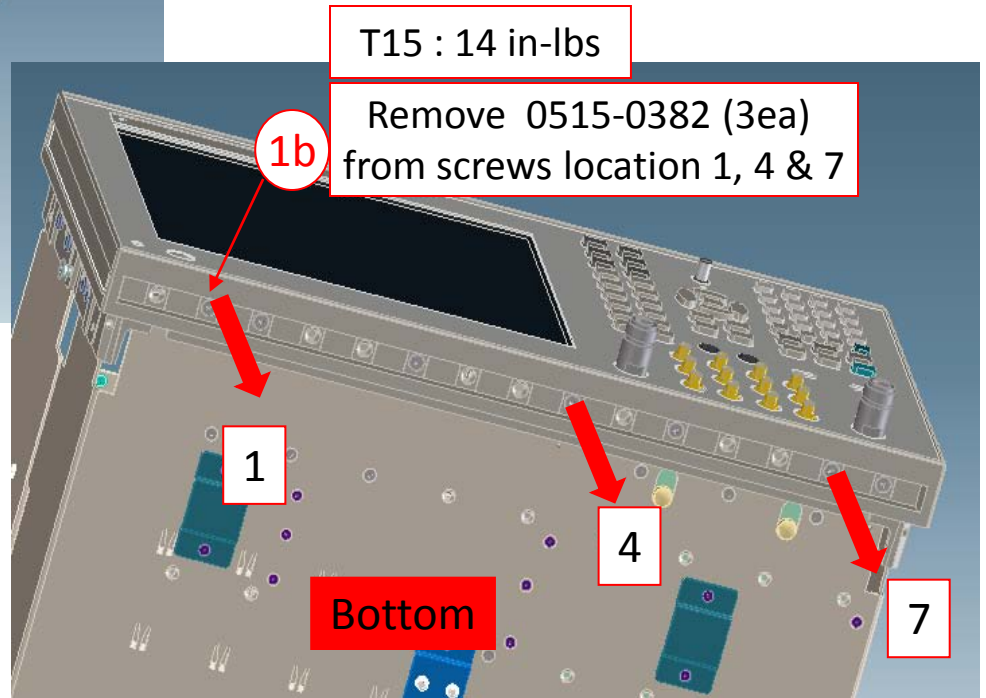
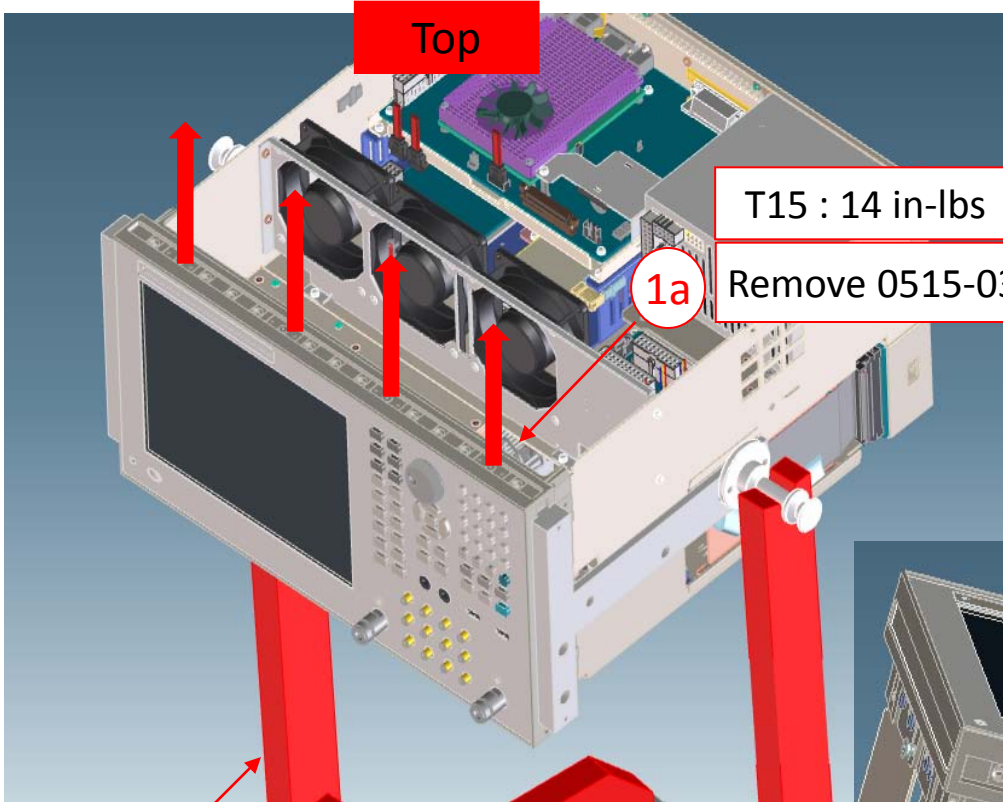

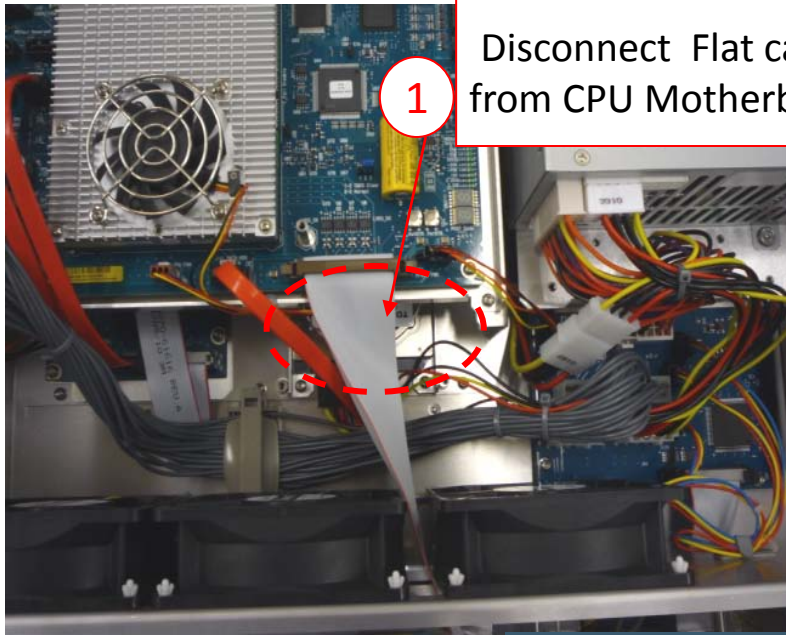

1 Disconnect Flat cable from CPU Motherboard

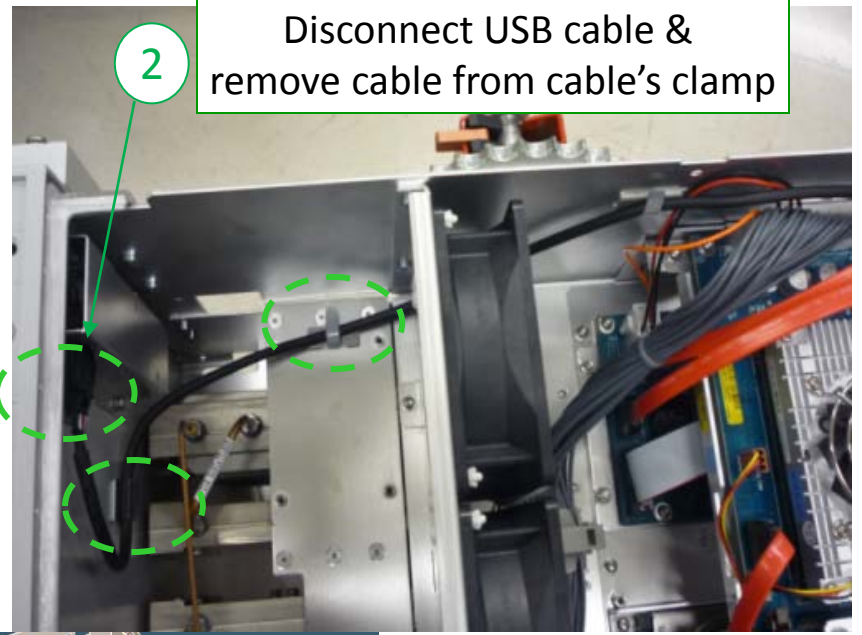

2 Disconnect USB cable & remove cable from cable's clamp

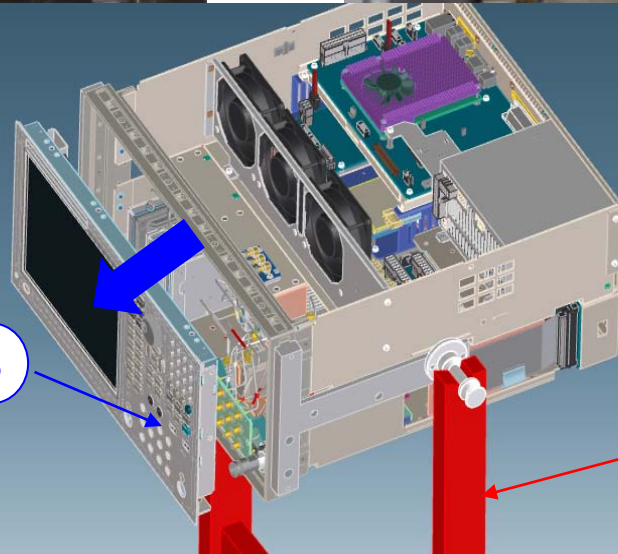

3 Slowly pull/remove Front frame Sub-assembly from Chassis

Hubic Cart used in F03 production

8mm Modified Hex Nut :
9.5 in-lbs

1 Remove Semi-Rigid cables

Remove Nut and Washer from
SMA connectors (4ea)

2

1 2

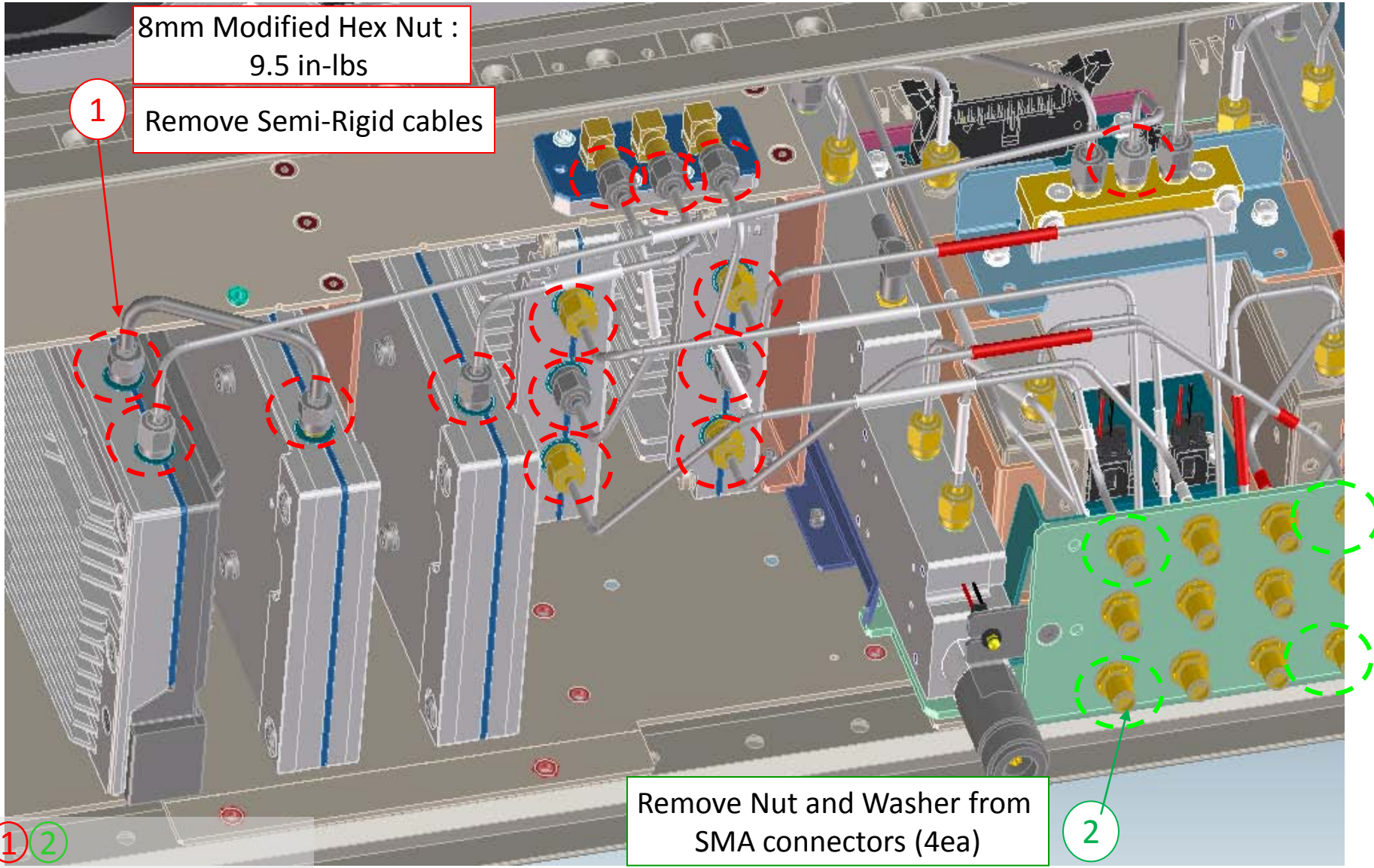

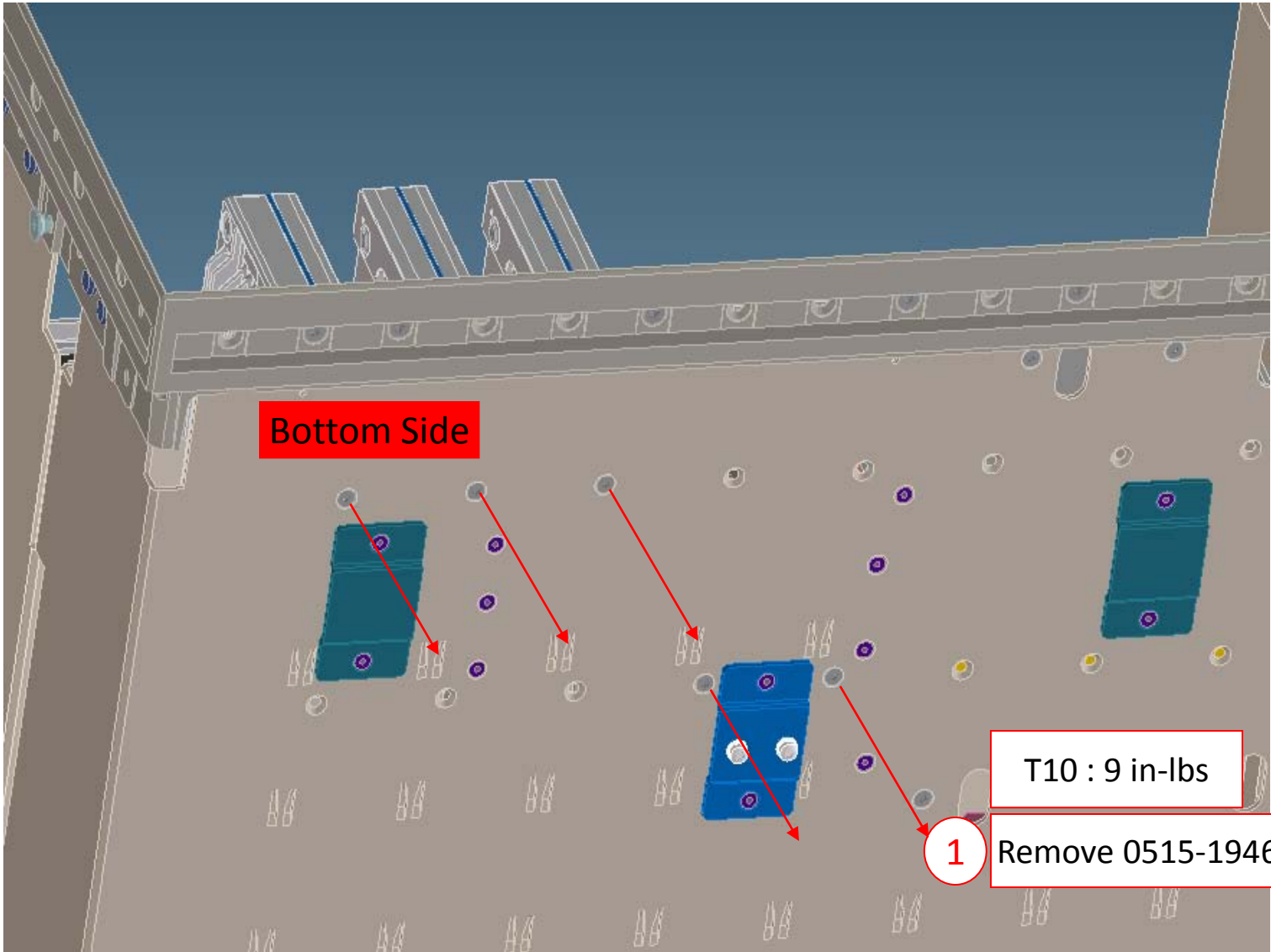

Bottom Side

T10 : 9 in-lbs

1

Remove 0515-1946 (5ea)

1

Remove A84 Module, E5072-61084

5

T10 : 9 in-lbs

4

Remove 0515-0372 (2ea)

3

Remove A2 Module, E5072-62002 (2ea)

2

Remove A91 Module, E5071-62191 (2ea)

1

Remove A83 Module, E5071-62183

- 1
- 2
- 3
- 4
- 5

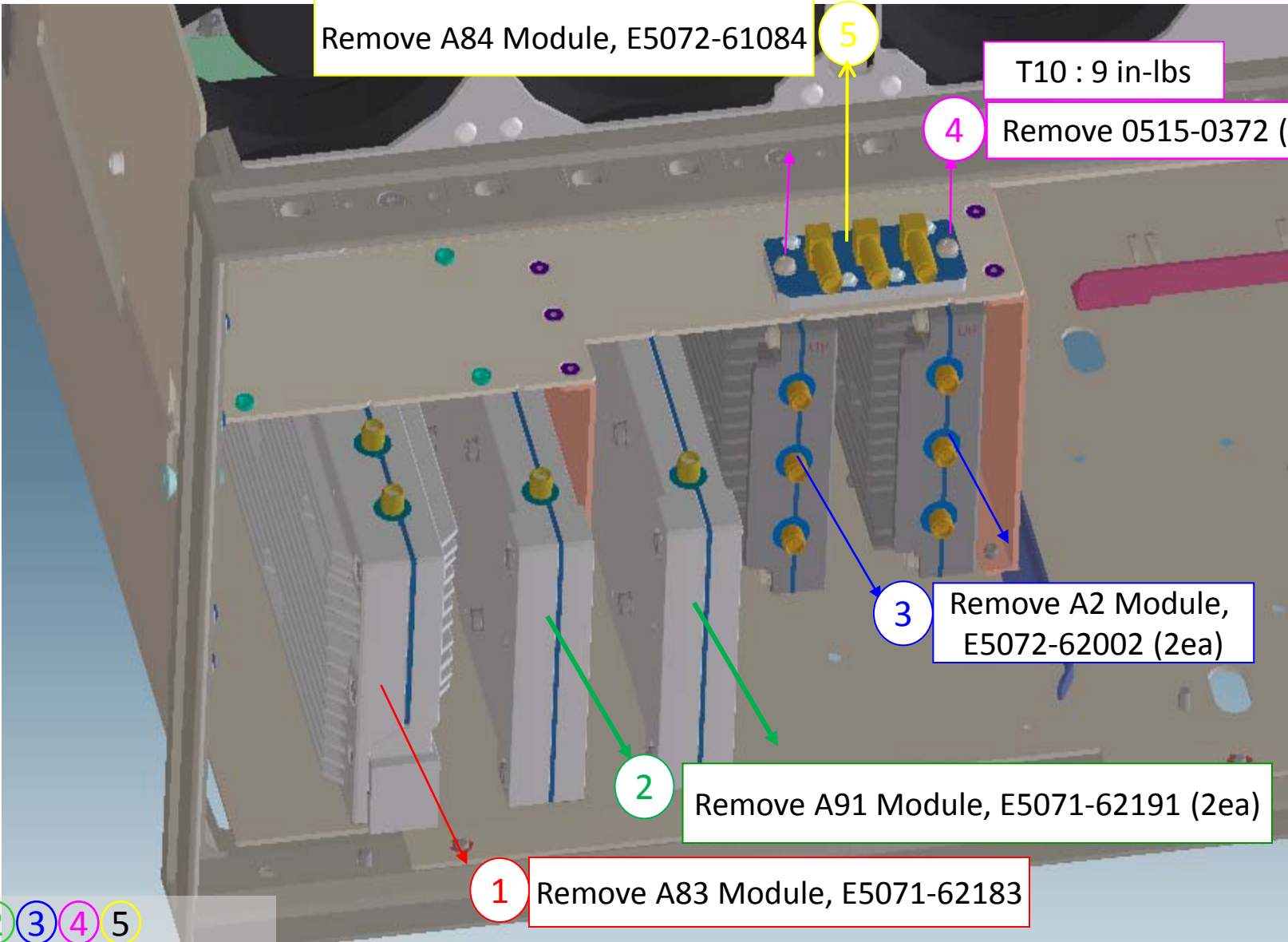

A50, Analog Motherboard (E5070-66650)

Dis-Assembly Procedure

Note:

1. Torque value shown in this document is only for reference and only used during assembly.

1 Remove 5041-9176

8mm Open End :
9.5 in-lbs

Remove E8356-20072 (6 ea) 3

Remove N5242-00030 2

Hubic Cart
used in F03
production

1 2 3

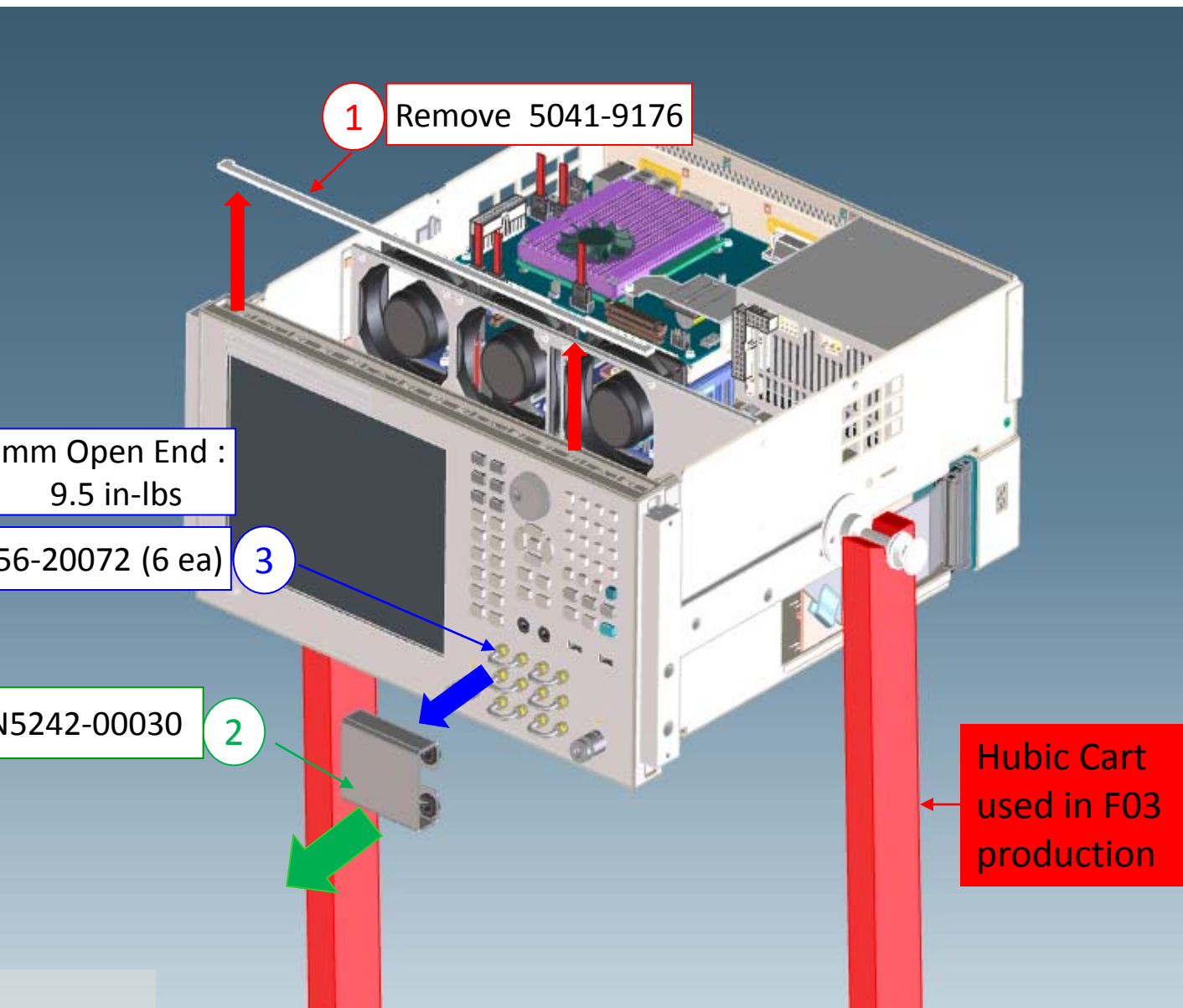

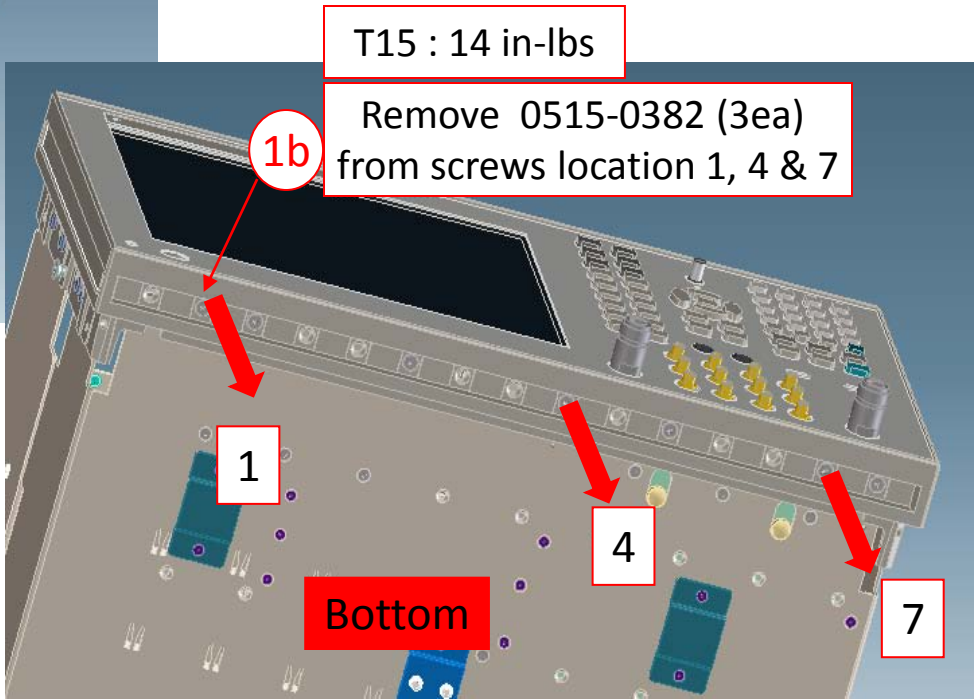
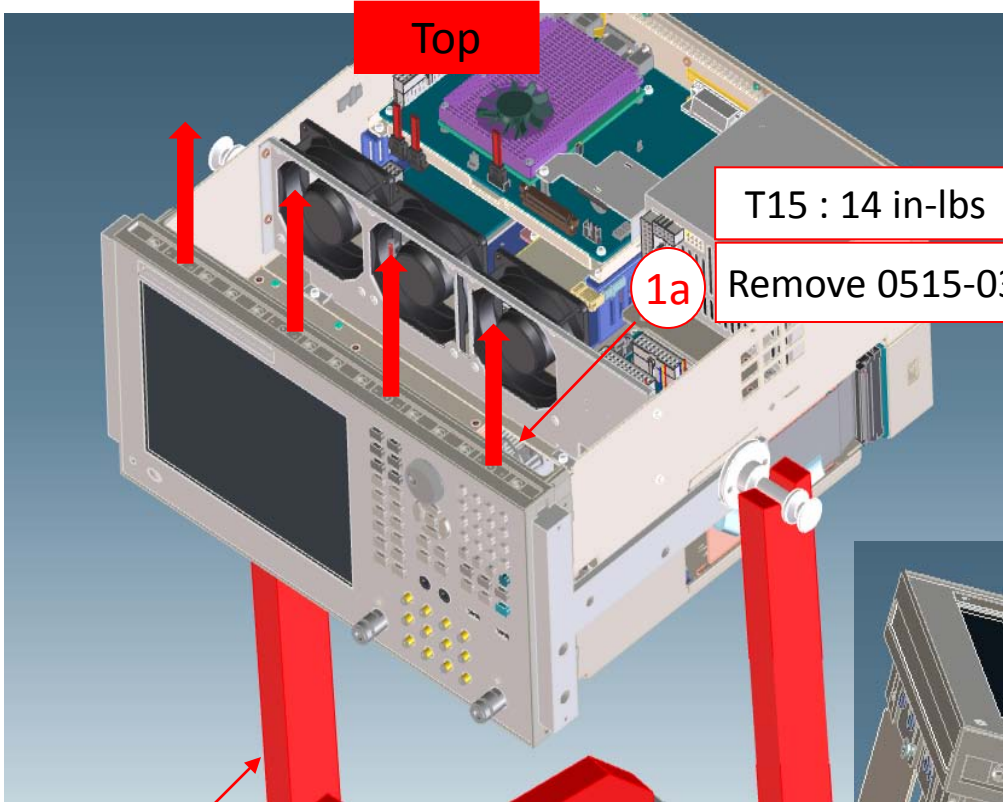

Hubic Cart
used in F03
production

①

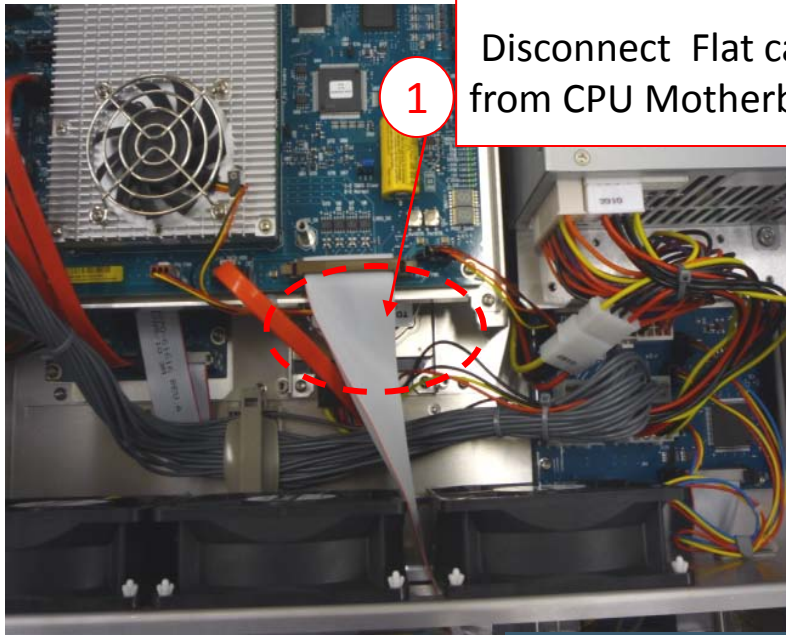

1 Disconnect Flat cable from CPU Motherboard

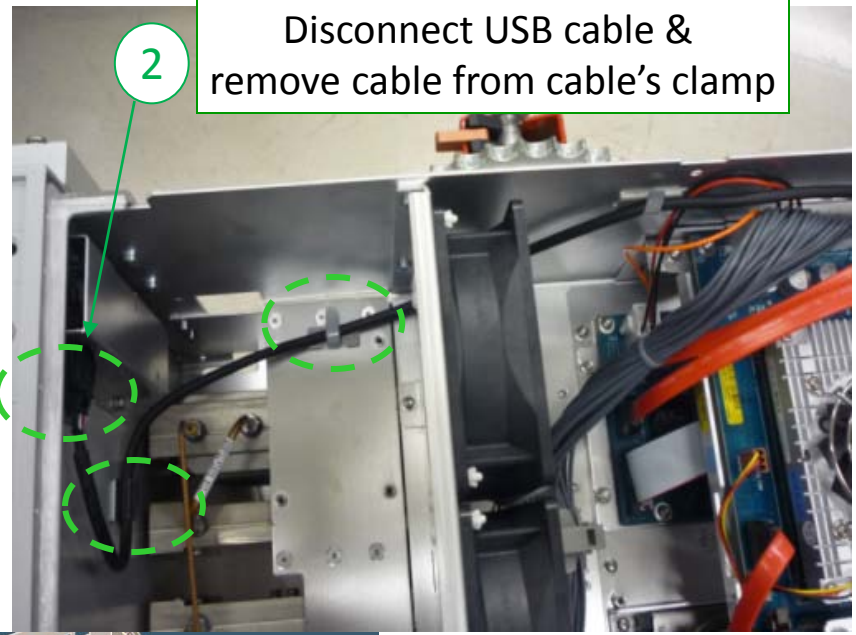

2 Disconnect USB cable & remove cable from cable's clamp

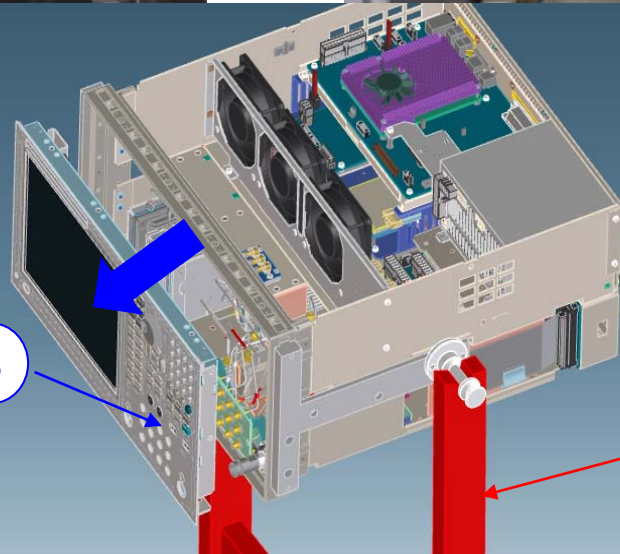

3 Slowly pull/remove Front frame Sub-assembly from Chassis

Hubic Cart used in F03 production

8mm Modified Hex Nut :
9.5 in-lbs

1 Remove Semi-Rigid cables

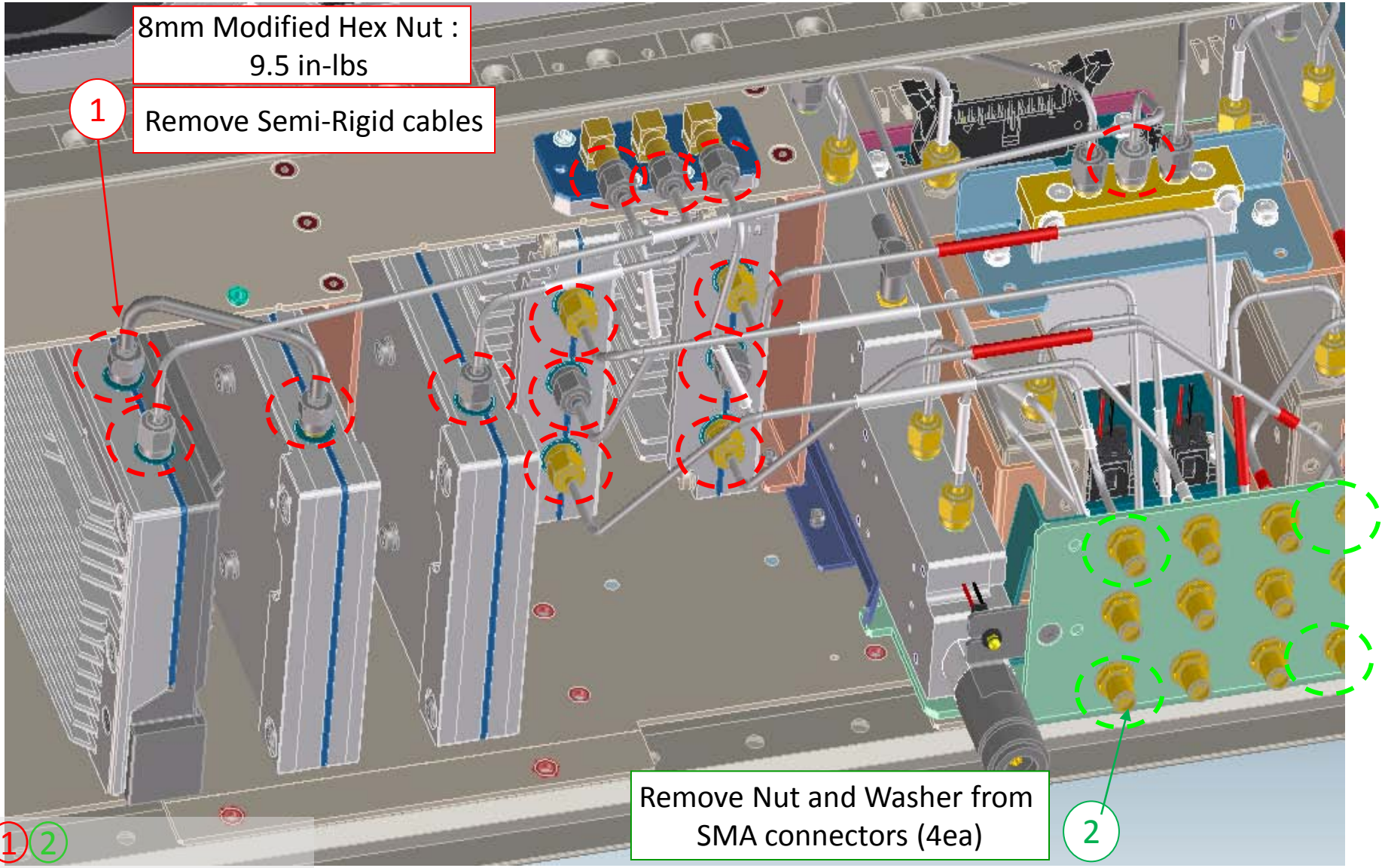

2 Remove Nut and Washer from
SMA connectors (4ea)

1 2

2

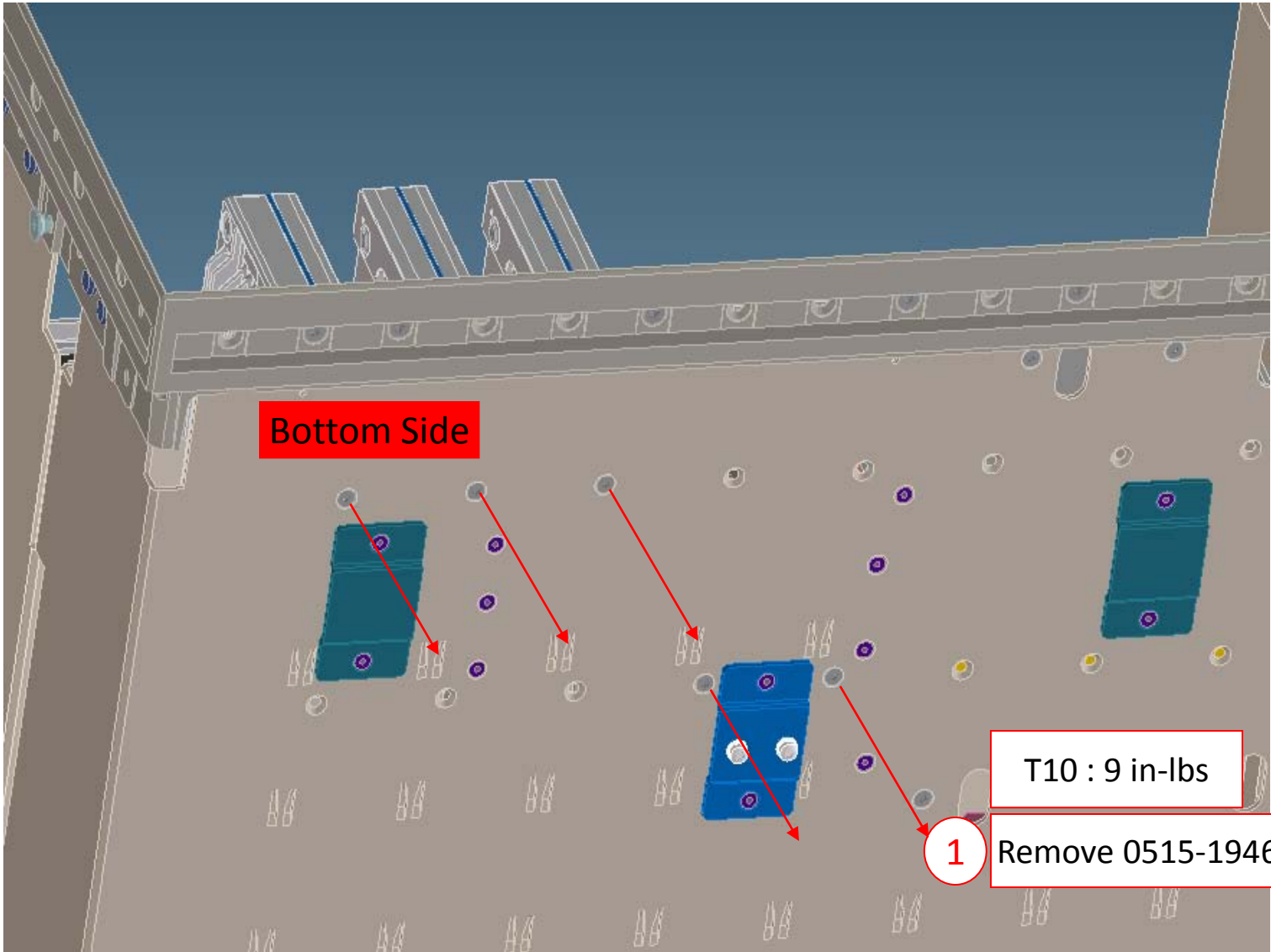

Bottom Side

T10 : 9 in-lbs

1

Remove 0515-1946 (5ea)

1

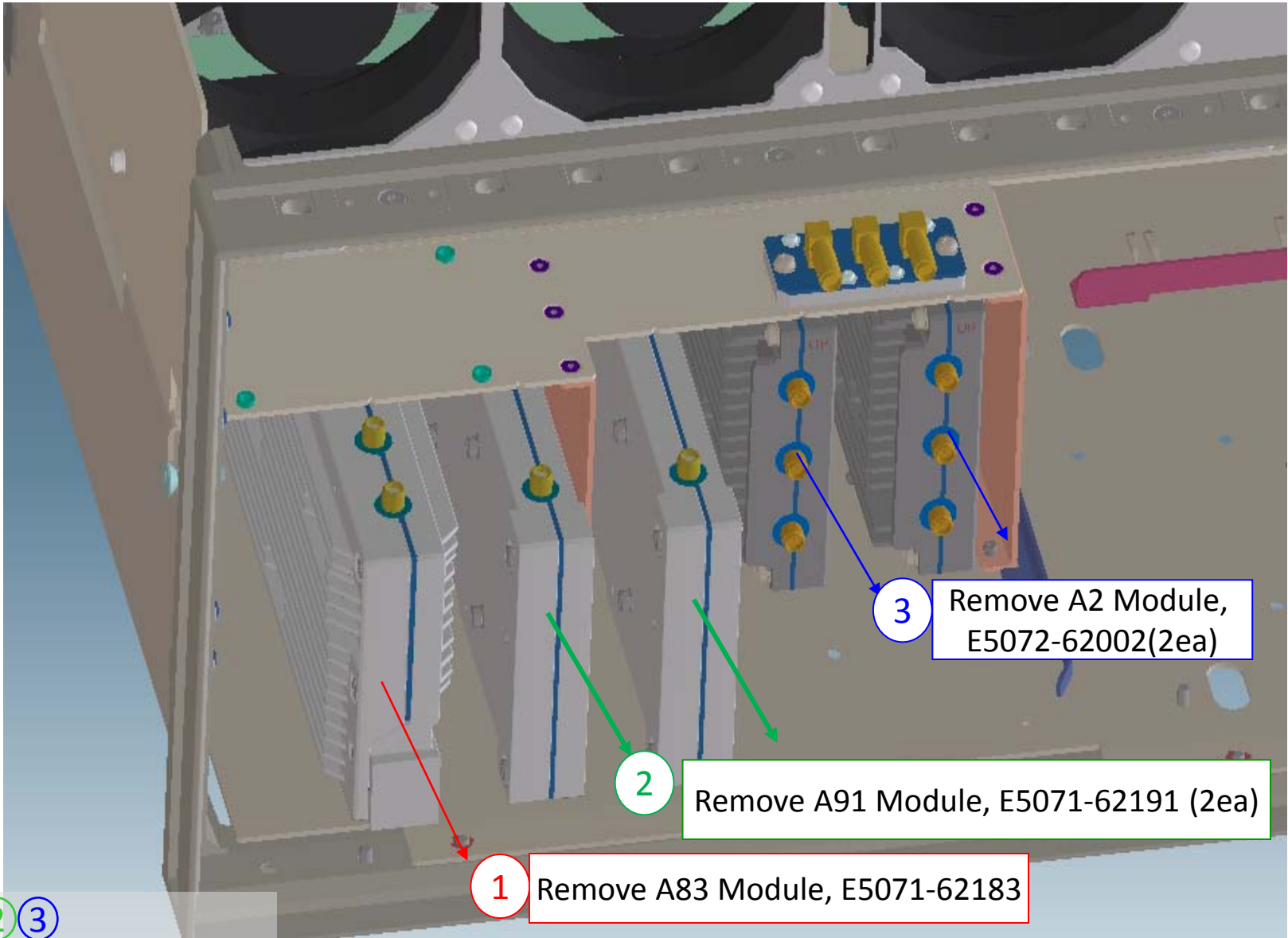

- ①
- ②
- ③

5/8 Torque box
30.4 in-lbs

Remove Nut, 2950-0054 (4ea)
& Washer, 2190-0054 (4ea)

T10 : 9in-lbs

Remove 0515-0430 (15ea)

2

3

Remove 0515-1946 (5ea)

T10 : 9in-lbs

1

4

Remove Rear panel
assembly from chassis

Hubic Cart
used in F03
production

1 2 3 4

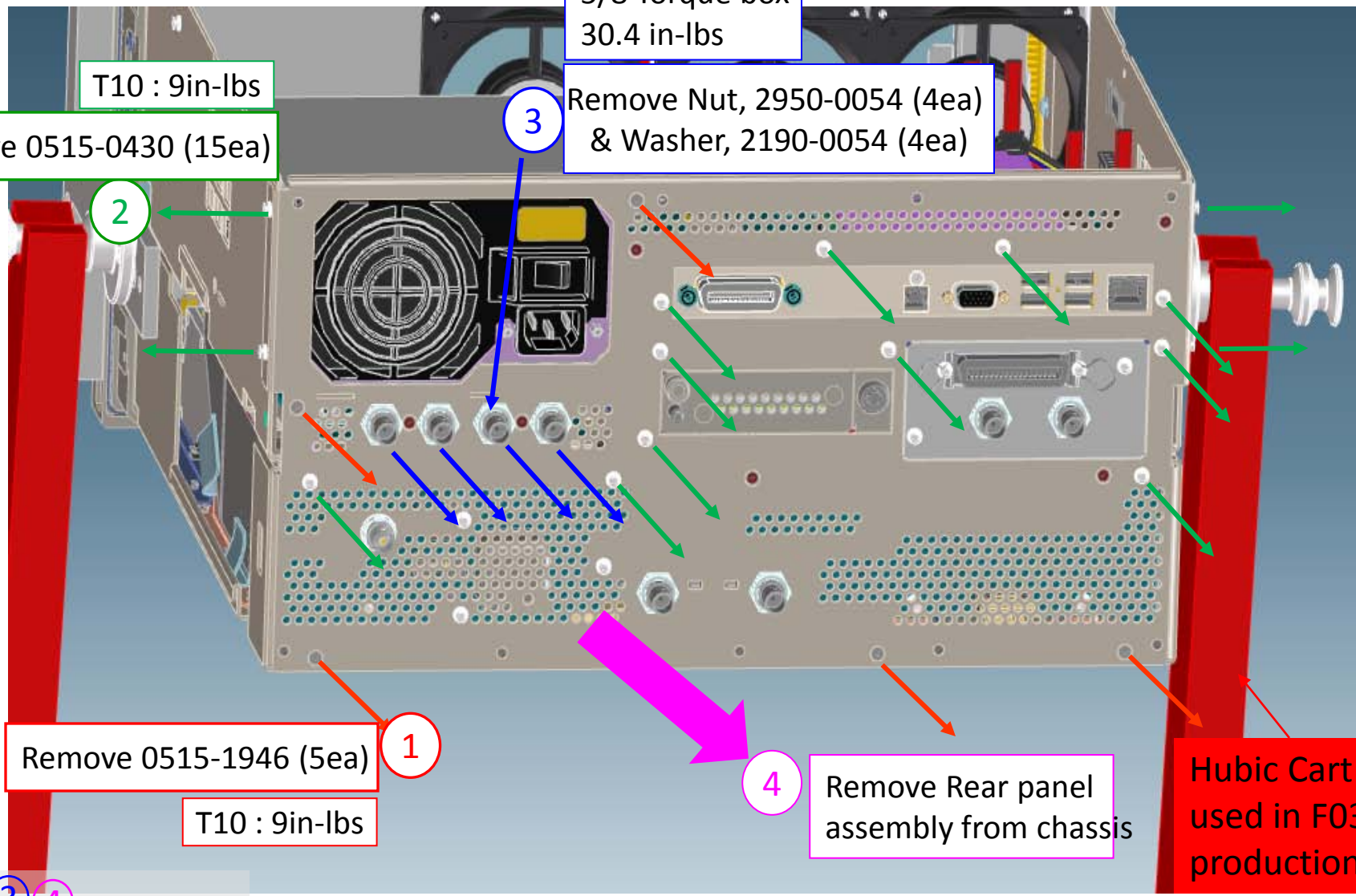

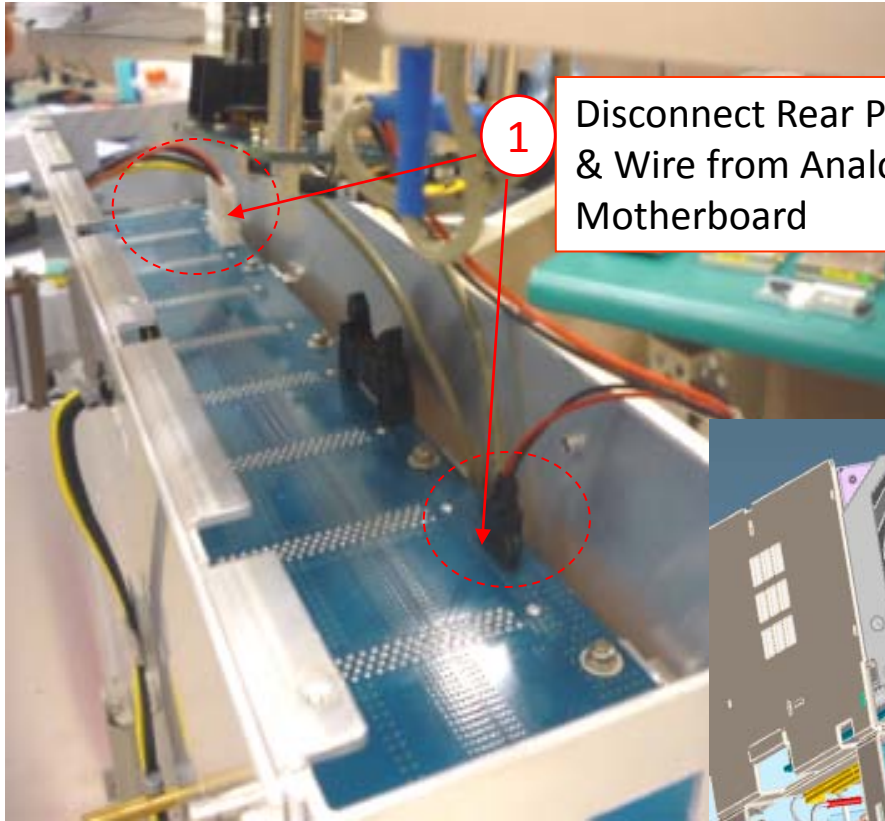

1 Disconnect Rear Panel's Cable & Wire from Analog Motherboard

T10 : 9 in-lbs

2 Remove 0515-0430 (10ea)

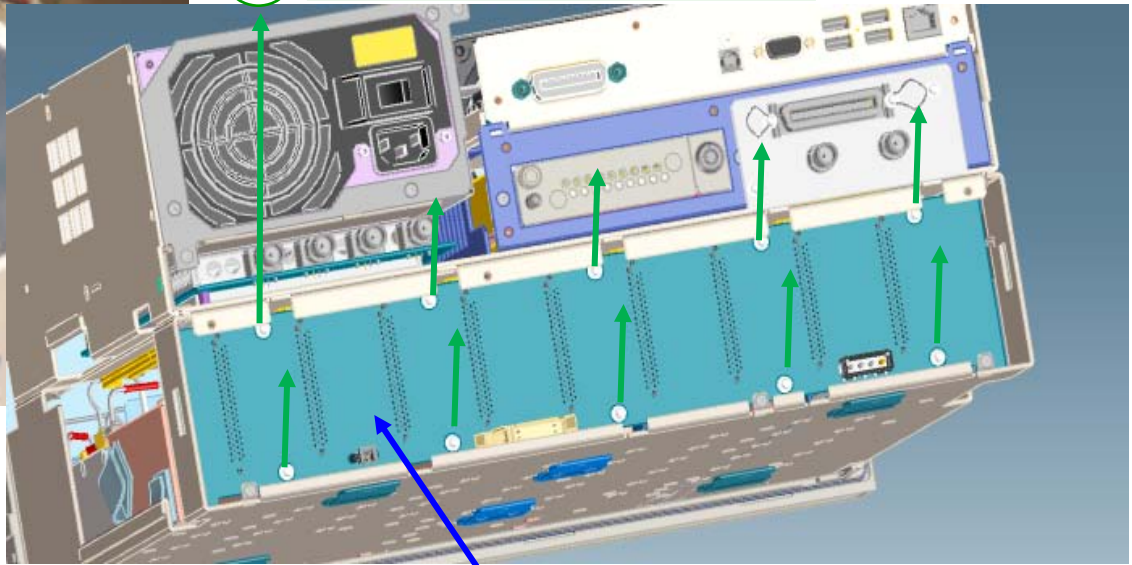

3 Remove E5070-66650 from chassis assembly

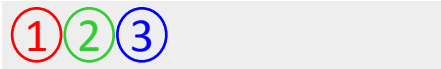

A92, RF Frontend Module (E5072-62092)

Dis-Assembly Procedure

Note:

1. Torque value shown in this document is only for reference and only used during assembly.

1 Remove 5041-9176

8mm Open End :
9.5 in-lbs

Remove E8356-20072 (6 ea) 3

Remove N5242-00030 2

Hubic Cart
used in F03
production

1 2 3

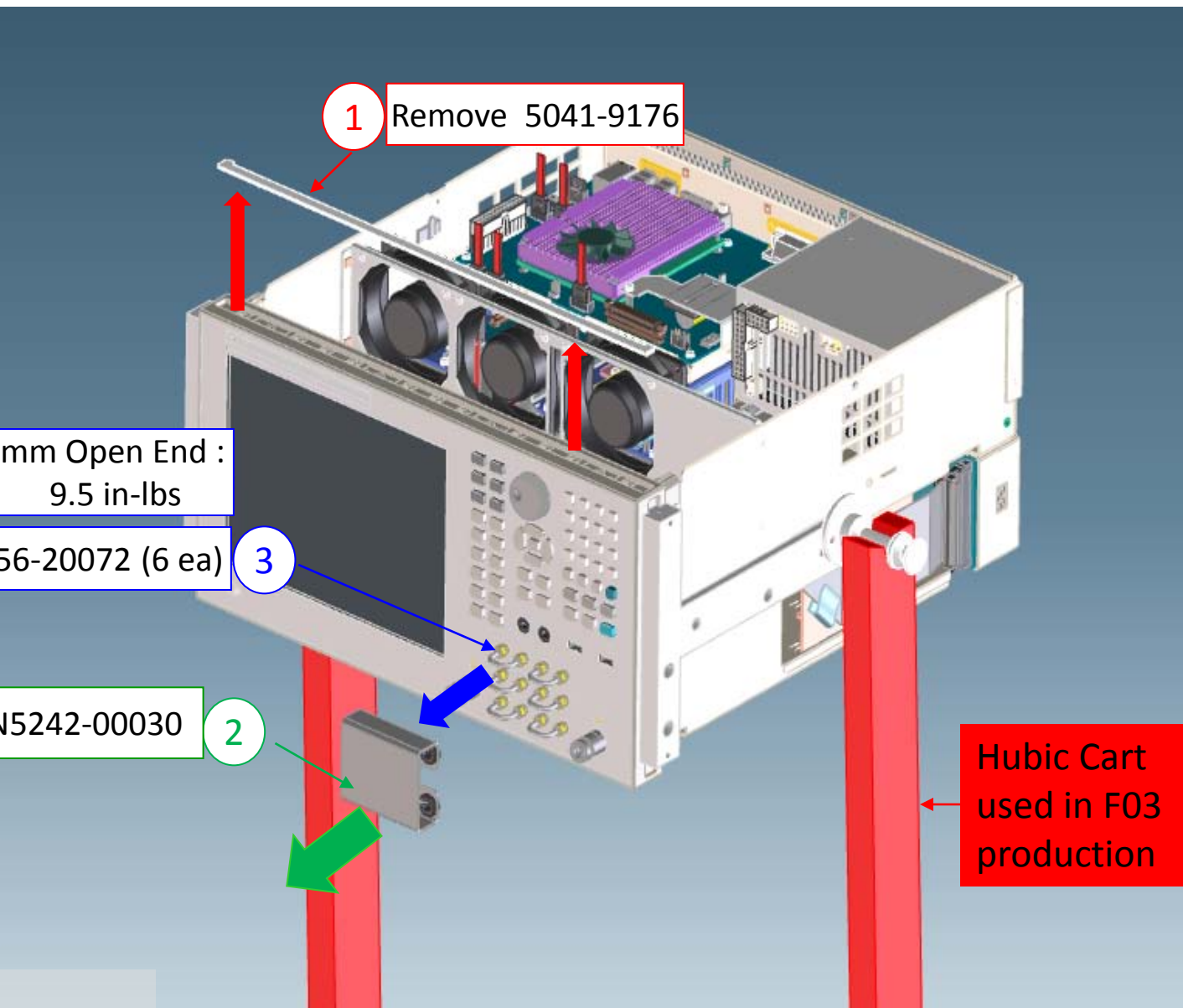

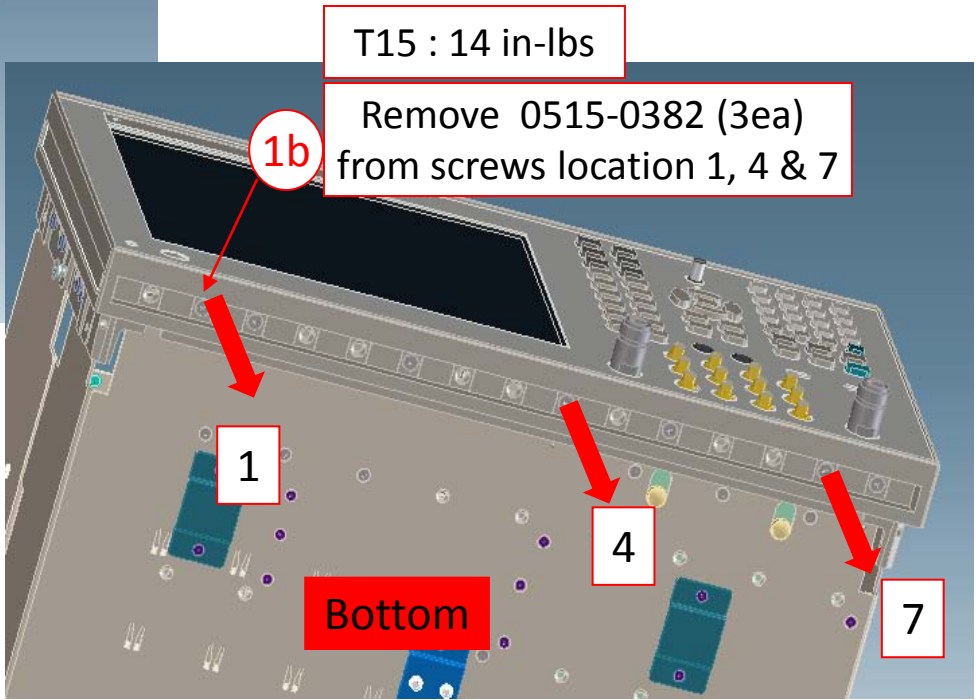
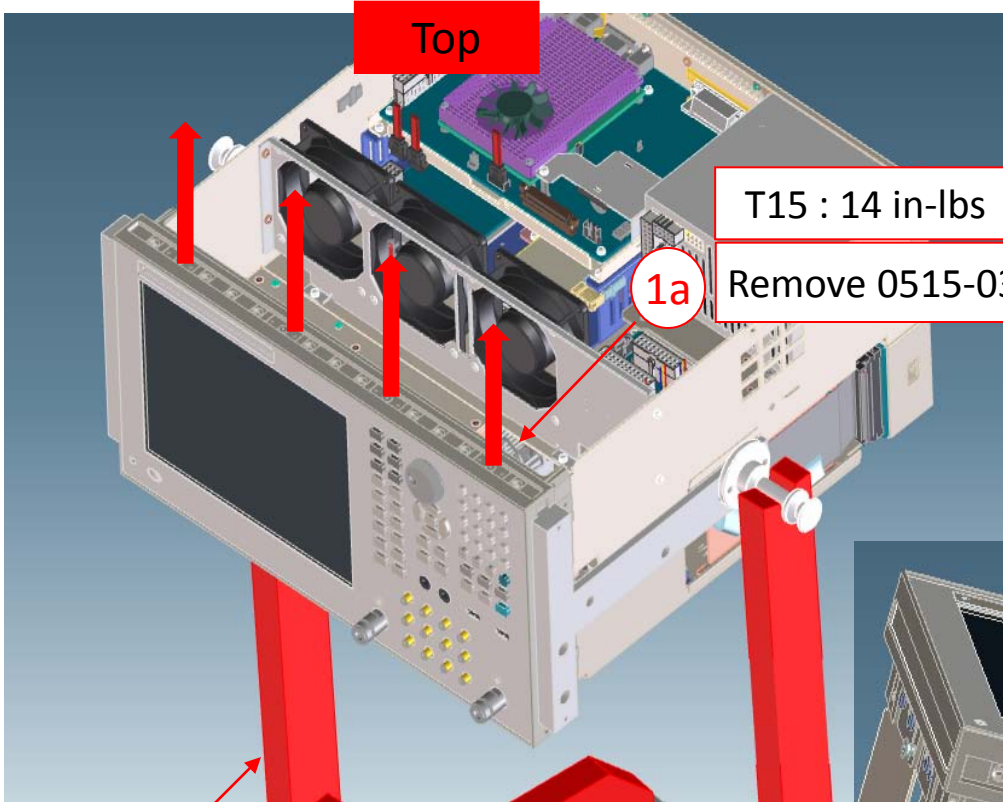

Hubic Cart
used in F03
production

①

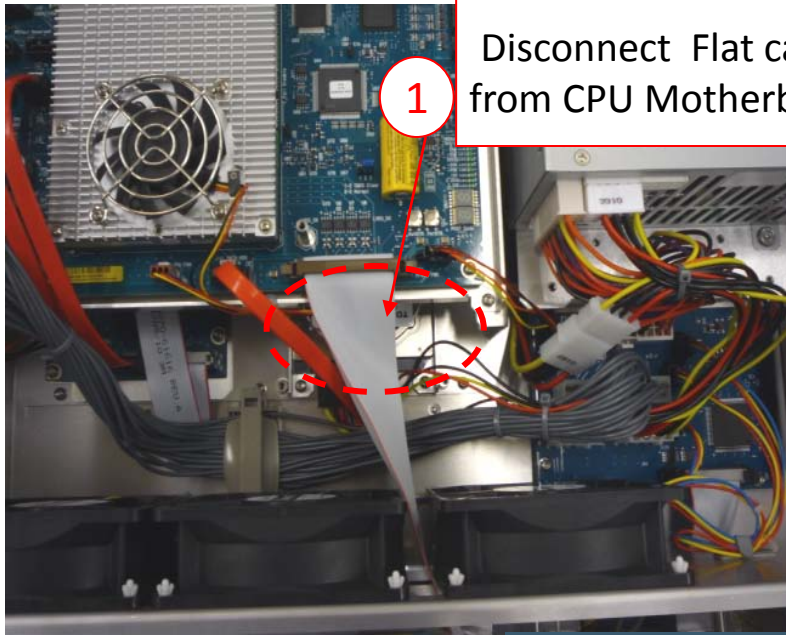

1 Disconnect Flat cable from CPU Motherboard

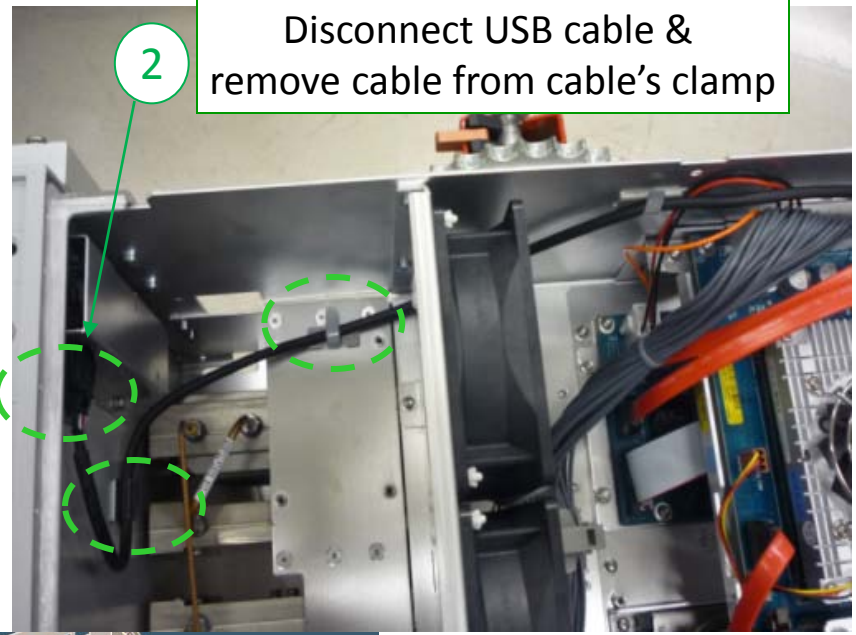

2 Disconnect USB cable & remove cable from cable's clamp

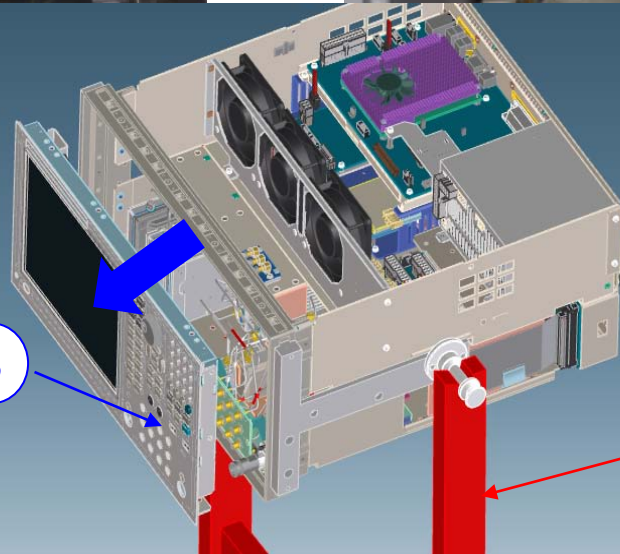

3 Slowly pull/remove Front frame Sub-assembly from Chassis

Hubic Cart used in F03 production

8mm Modified Hex Nut :
9.5 in-lbs

1 Remove Semi-Rigid cables

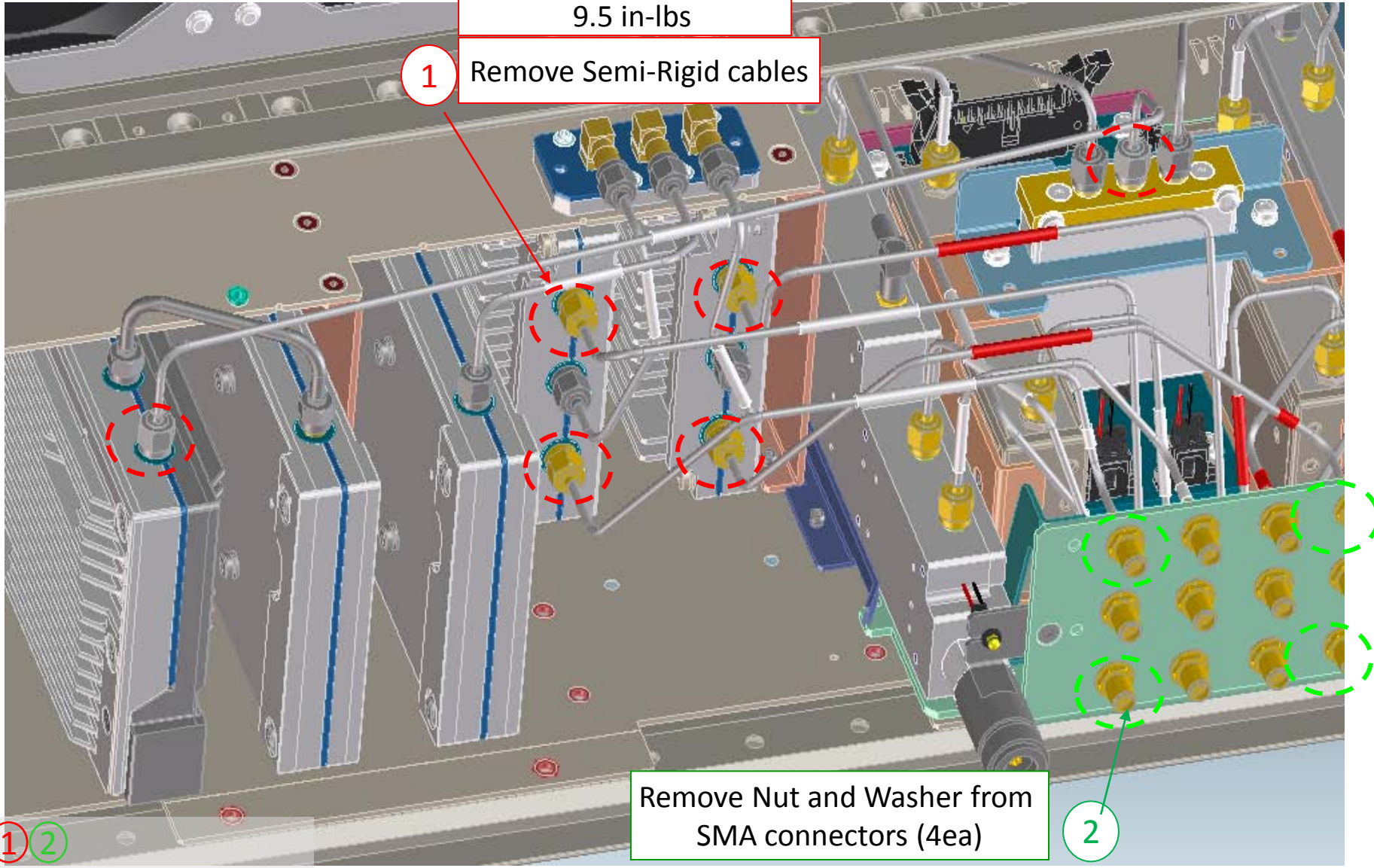

Remove Nut and Washer from
SMA connectors (4ea)

2

1 2

Disconnect RF cables

1

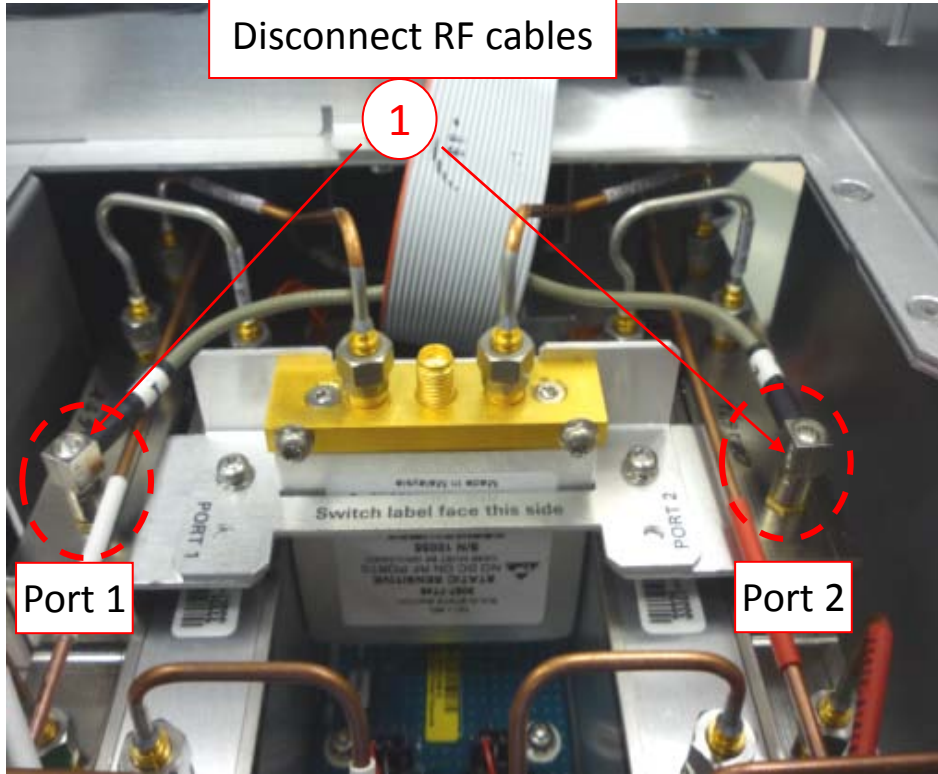

Port 1

Port 2

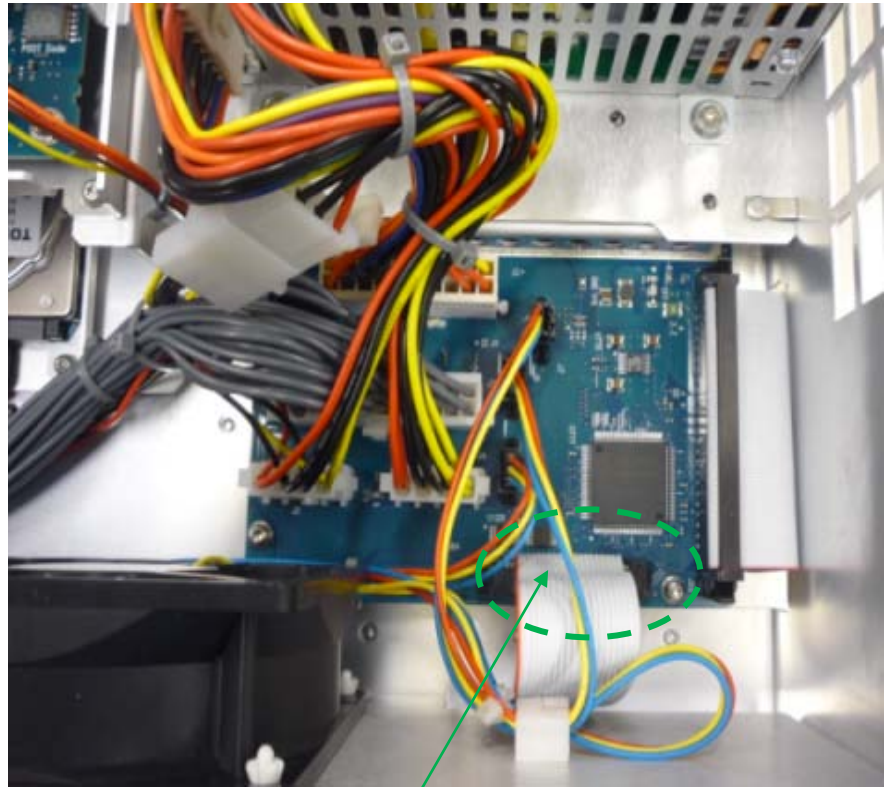

Disconnect cable, E5072-61622

2

1 2

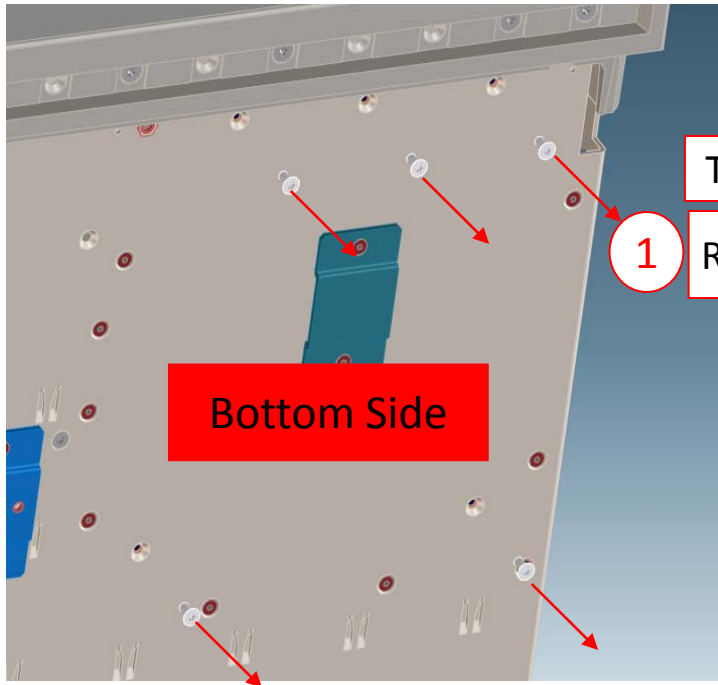

T10 : 9 in-lbs

1

Remove 0515-1946 (5ea)

Bottom Side

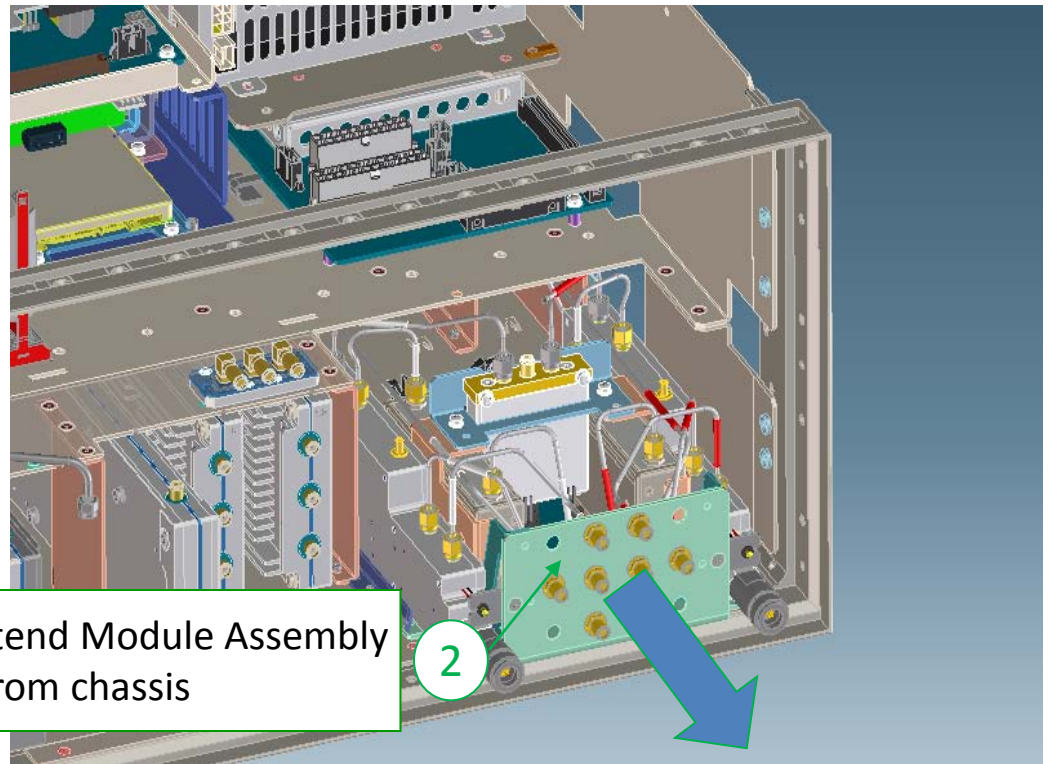

Pull out Frontend Module Assembly
from chassis

2

1 2

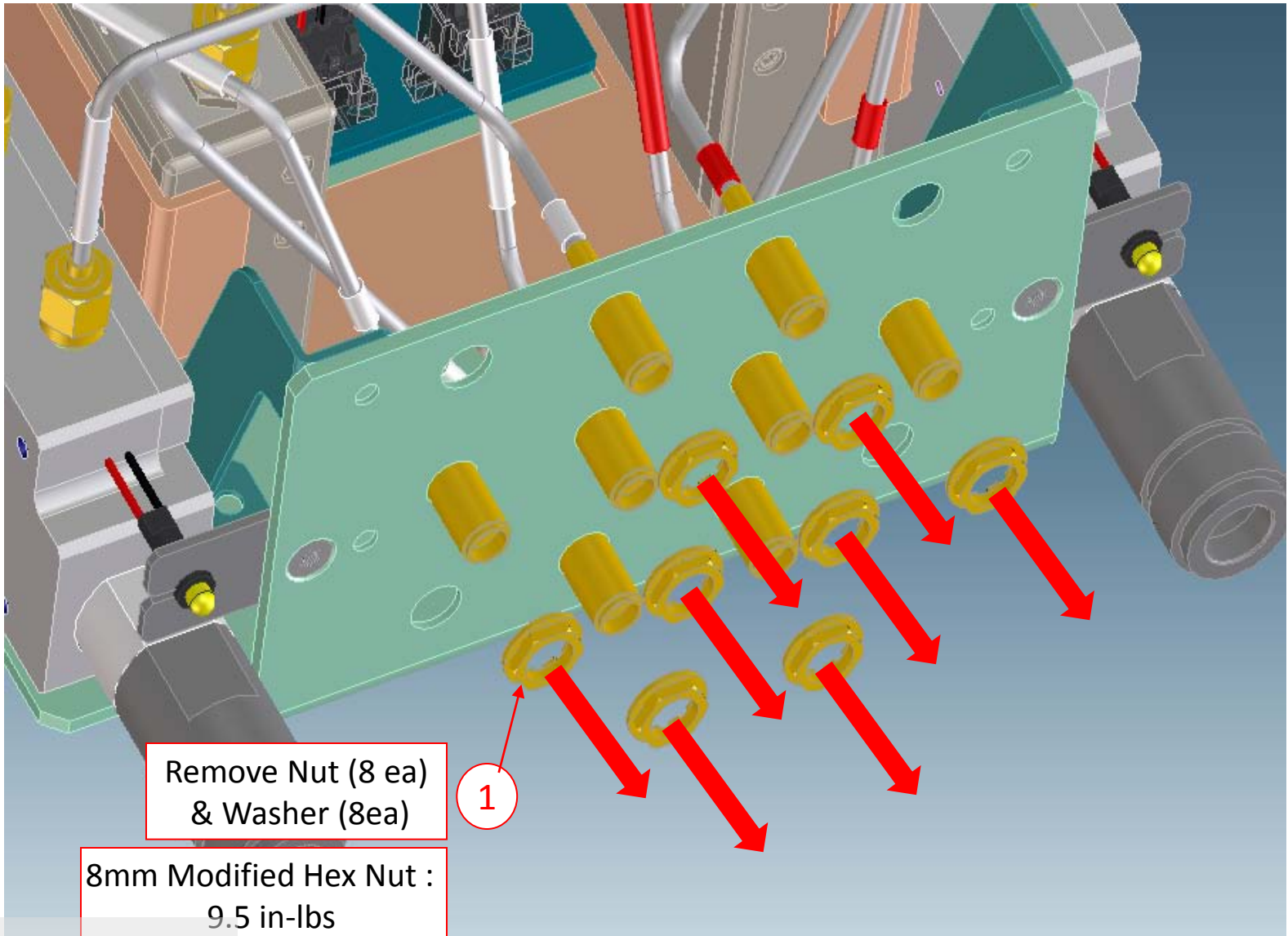

Remove Nut (8 ea)
& Washer (8ea)

8mm Modified Hex Nut :
9.5 in-lbs

①

①

8mm Open End :
9.5 in-lbs

Remove Semi-Rigid cables

1

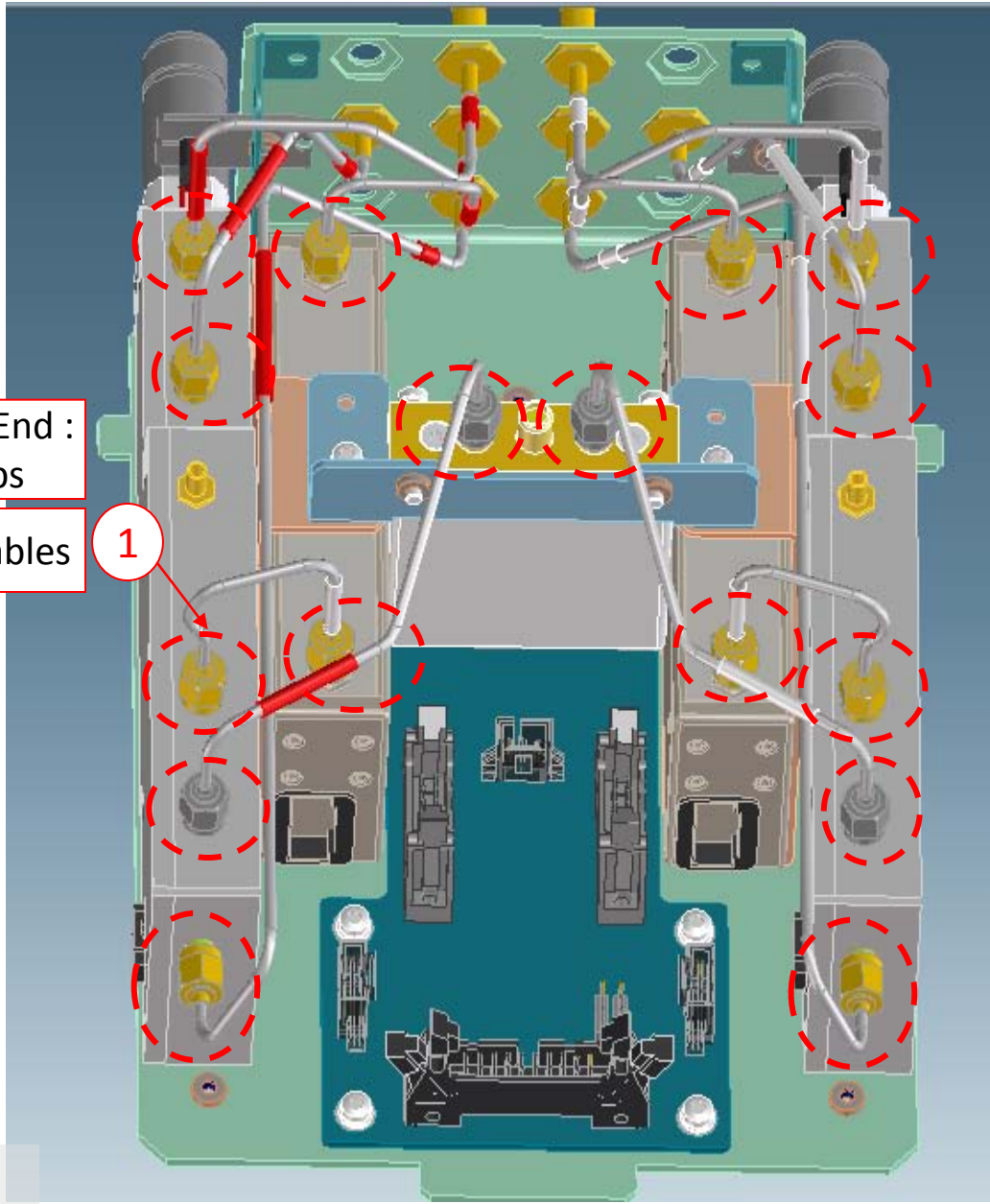

1 2

T10 : 9 in-lbs

Remove 0515-1946 (8ea)

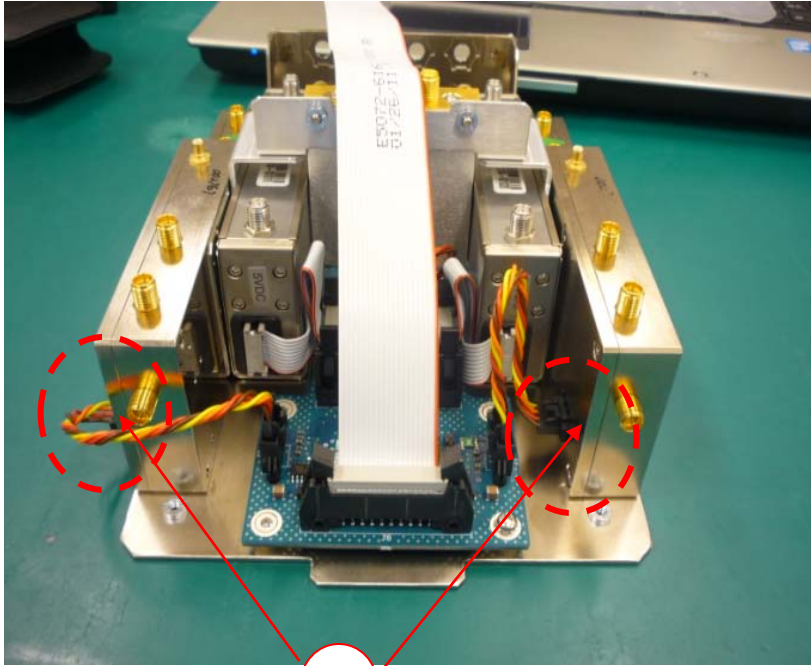

1

Disconnect E5072-61629 (2ea)

2

Bottom Side

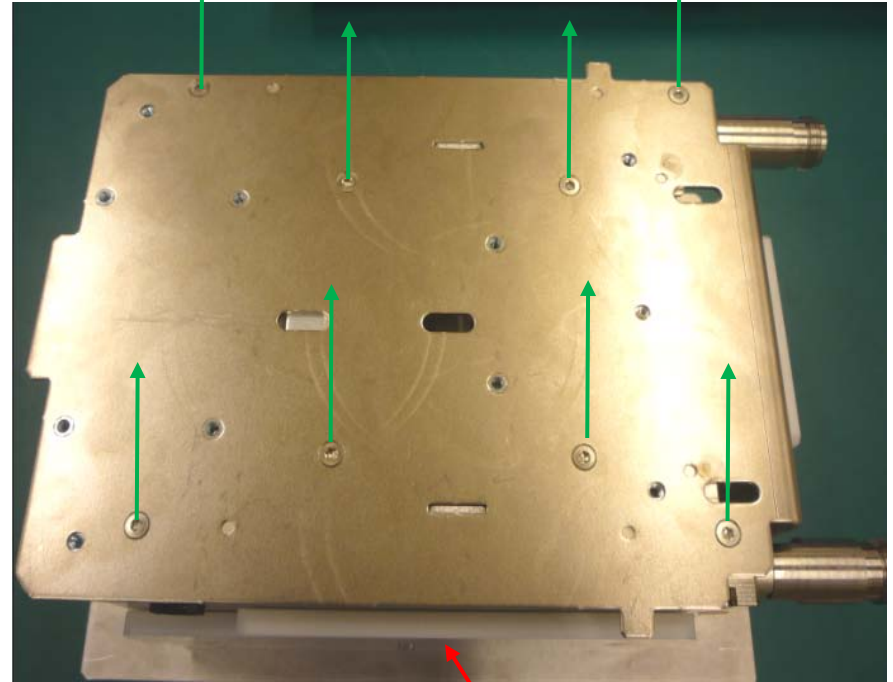

Front-End Module Jig,
T-384208

1 2

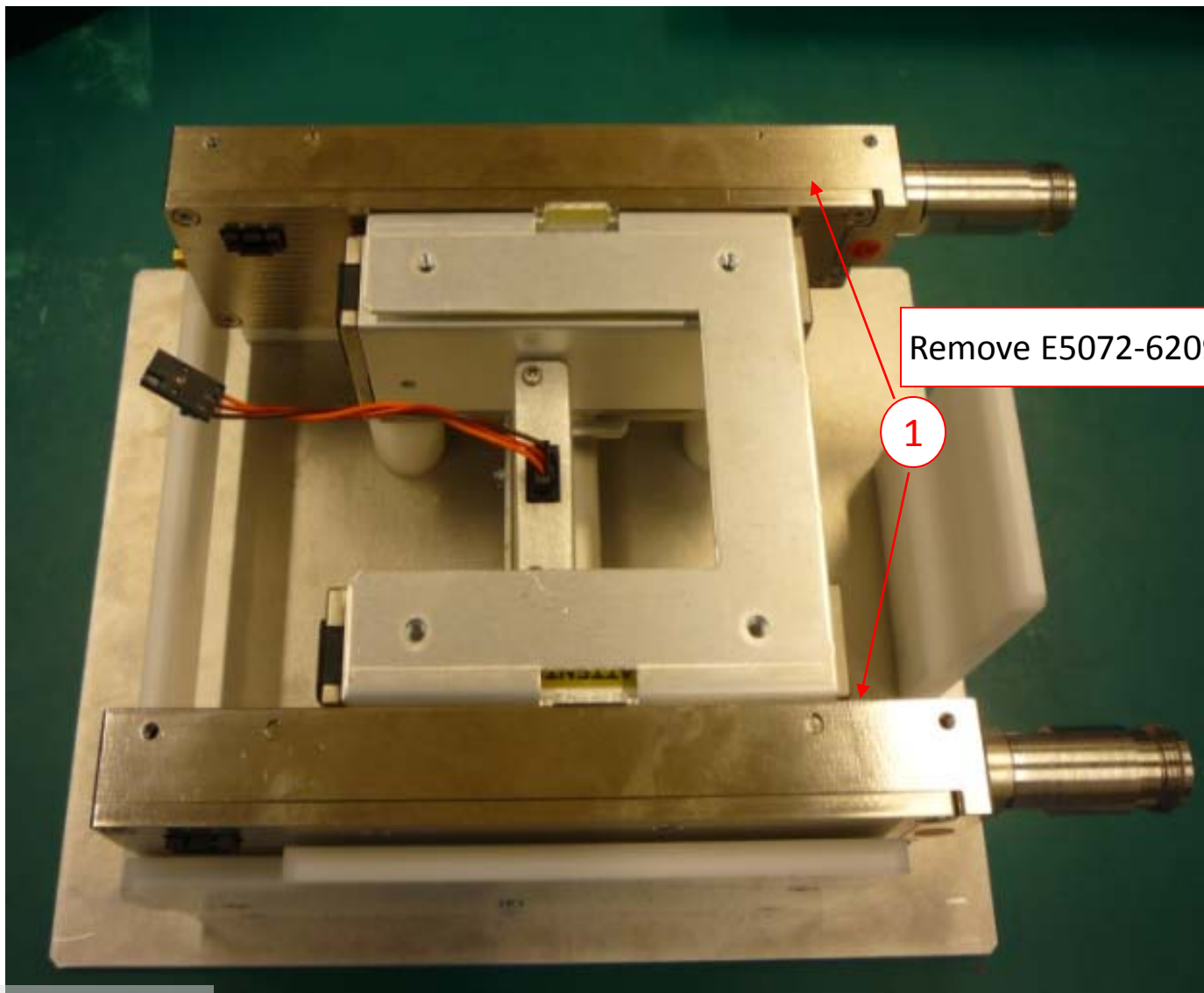

Remove E5072-62092 Module (2ea)

1

1